



GOVERNMENT OF THE REPUBLIC OF INDONESIA
MINISTRY OF PUBLIC WORKS
DIRECTORATE GENERAL OF WATER RESOURCES DEVELOPMENT

PROGRAMME OF ASSISTANCE FOR THE IMPROVEMENT
OF HYDROLOGIC DATA COLLECTION, PROCESSING
AND EVALUATION IN INDONESIA

SUSPENDED LOAD

Sampling and Measurement

by

M. Travaglio



SOCIETE CENTRALE
POUR L'EQUIPEMENT
DU TERRITOIRE
INTERNATIONAL

SUSPENDED LOAD

Sampling and Measurement

by

M. Travaglio

Bandung, May 1981

Table of Contents

	Page
List of Symbols used in the text	
I. Introduction	1
II. Vertical Distribution of Suspended Sediment	5
General considerations	5
Depth integrating method	8
Point integrating method	9
III. Integrating Samplers	10
Depth integrating samplers	11
Transit rate	11
U.S. Depth integrating samplers (DH 48, DH 59, D 49)	13
Point integrating samplers (US P61, US P63, Turbidisonde, Delft bottle)	17
IV. Practical Observations about the Use of the U.S. Silt Samplers .	23
Transit rate	23
Nozzles	27
Gaskets	28
Bottles	29
V. Lateral Distribution of Suspended Sediment	31
Site selection	32
Number of sampling verticals	36
The Equal Discharge Increment method	38
The Equal Transit Rate method	41
VI. Other Measurement Devices	43
Instantaneous samplers	43
Single stage sampler (US 59, Gluschkoff bellows, Pumping samplers)	45
ORSTOM procedure	47
Photoelectric turbidity method	48

VII	Concluding Remarks	49
	Annex I	51
	Annex II	56
	Annex III	59
	References	63

List of Symbols

Q_s	:	suspended sediment discharge for the whole cross section in weight per unit time
q_s	:	suspended sediment discharge at a given vertical in weight per unit time and unit width
Q	:	water discharge for the whole cross section in volume per unit time
q	:	water discharge at a given vertical in volume per unit time and unit width
u	:	velocity at a given point
\bar{u}	:	mean velocity at a given vertical
c	:	concentration at a given point in the cross section
\bar{c}	:	mean concentration at a given vertical
\bar{C}	:	mean concentration for the whole cross section
y	:	distance above channel bed
x	:	distance from an origin along the cross section for a given vertical
a	:	sampler nozzle area
L	:	channel width
D	:	total depth at a given vertical
R_t	:	transit rate in the depth-integrating method
w	:	weight of sediment in a sample
v	:	volume of water-sediment mixture of a sample
\bar{U} or \bar{V}	:	mean velocity for the whole cross section
\bar{D}	:	mean depth for the whole cross section

I. INTRODUCTION

The suspended load is made up of particles which move in suspension with the flow at the same average velocity. It includes the suspended part of the bed material load and the washload, the latter being made up of grain sizes finer than the bulk of the bed material. Einstein suggested that the limiting sizes of washload and bed material load may be chosen quite arbitrarily as the grain diameter of which 10 percent of the bed material is finer.

The washload is supplied from the watershed through a sheet erosion process and is usually not a function of the stream discharge, therefore it is necessary to measure suspended load rates for numerous flood hydrographs both during rising and falling stages and during different seasons.

To illustrate the foregoing two figures are presented hereafter. Fig. 1 shows a clear relationship between the bed material discharge and the mean velocity, however from fig. 1' no definite relationship between washload and water discharge can be established, it can only be said that the general trend is that the washload is small when the stream flow is low and conversely.

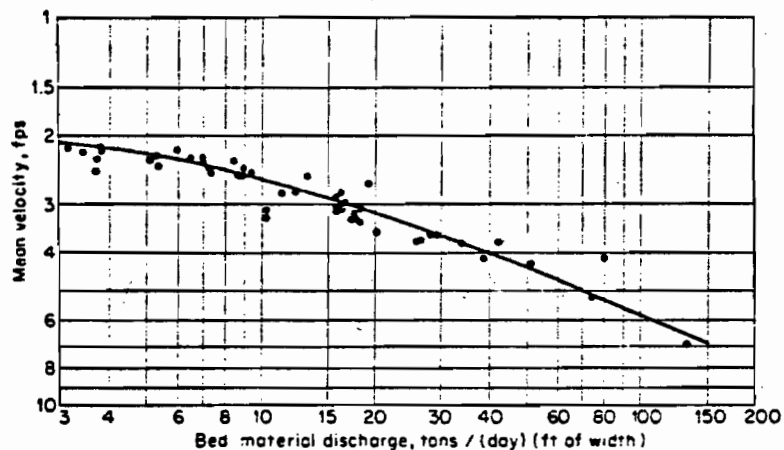

Fig. 1 Bed material load vs. mean velocity—Niobrara River. [After COLBY (1963).]

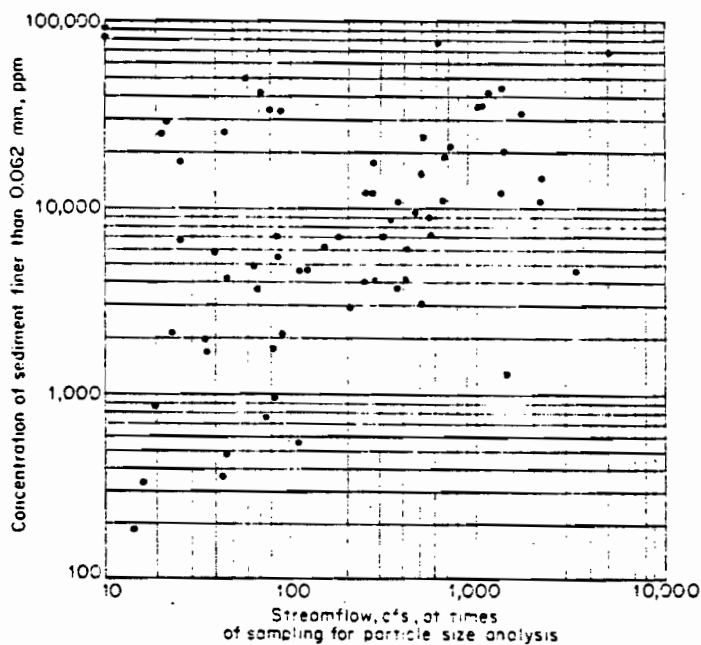

Fig. 1! Washload vs. streamflow—Powder River. [After COLBY (1963).]

Let us consider a cross section in a given stream (fig. 2). On the assumption that suspended particles are carried along by the stream with the same average velocity then for a small area where both concentration and velocity may be considered as constant the sediment discharge may be expressed as the product of the water discharge and the concentration. Since the water discharge is the product of the area times the velocity it follows that the sediment discharge in weight through the small area surrounding a point M can be expressed in the form of :

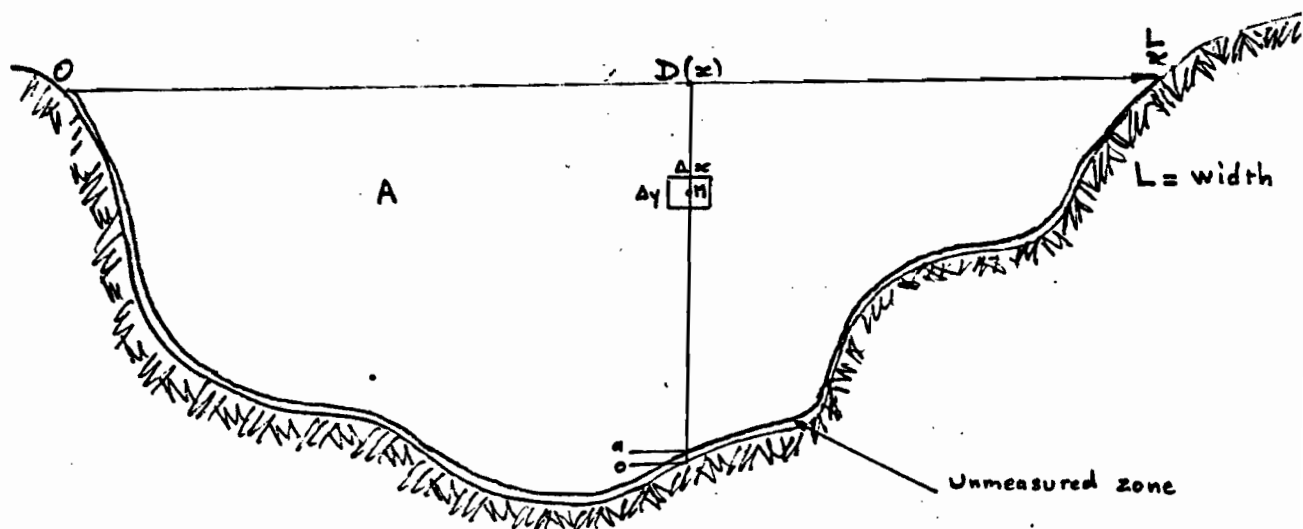

Figure 2

$$\Delta Q_s = cu \Delta x \Delta y \quad (1)$$

and by integrating through the whole cross-section A we obtain :

$$Q_s = \iint_A du dx dy \quad (2)$$

Let us make a partition of the cross section A with the verticals so that to express Q_s in the form of a twofold iterated integral, namely :

$$Q_s = \int_0^L dx \int_a^{D(x)} cu dy \quad (3)$$

where

$\int_a^{D(x)} cu dy$ is the sediment discharge in weight per unit width for the vertical x which is denoted q_s .

So if for a sufficient number of points in the cross section both velocities and concentration are known the sediment discharge can be calculated by means of graphical integration. Actually measuring concentrations and velocities at the same time is both awkward and time consuming. Moreover in most cases a stage-discharge rating curve is available and the point is to get the mean concentration for several verticals without having to measure the velocities.

Remarks : The suspended sediment cannot be measured right to the bed since the sampler nozzle cannot reach the lower 10 to 15 cm of a vertical so the lower limit in the integral $\int_a^D cu dy$ is a and not zero. So there is an unmeasured part (see fig. 3) from the bottom to a height, a , which may or may not be a sizeable part of the total load.

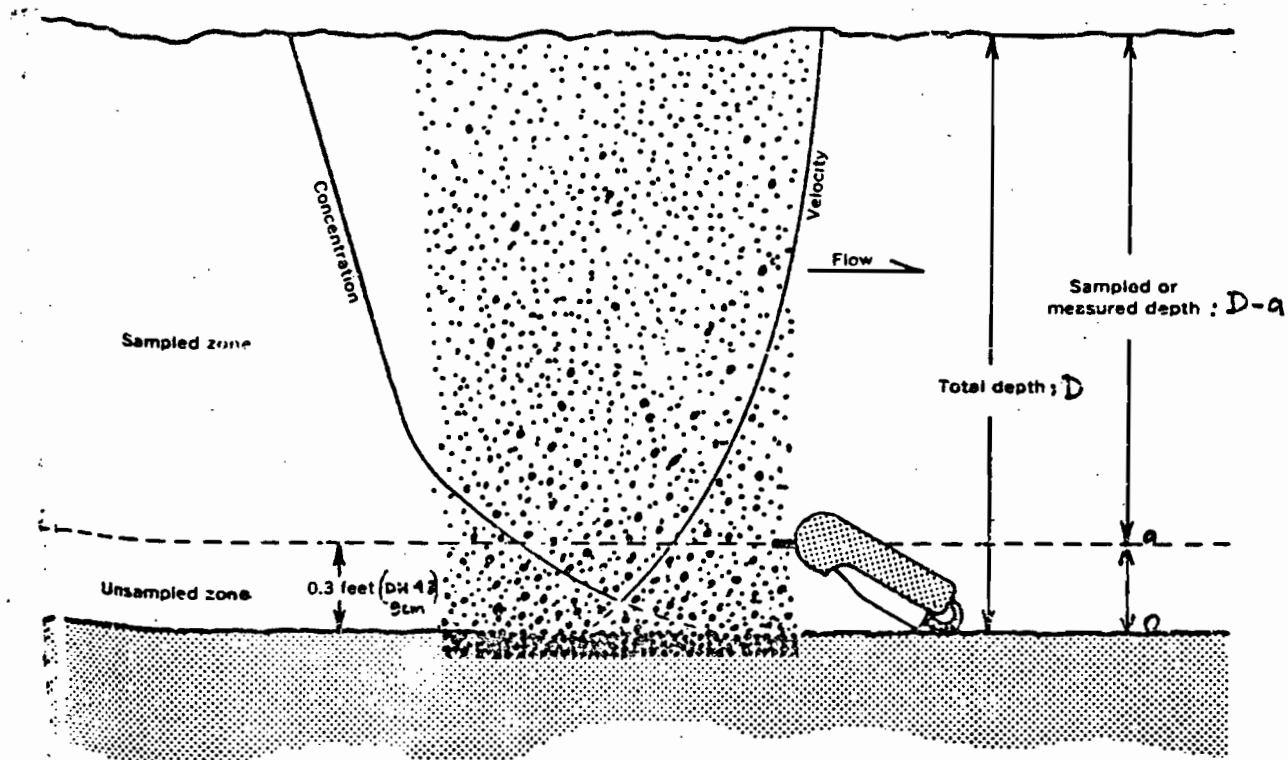

Fig. 3 — Measured and unmeasured sampling zones in a stream sampling vertical with respect to velocity of flow and sediment concentration. J. K. Cuibertson (Written commun., May 1968).

VI. VERTICAL DISTRIBUTION OF SUSPENDED SEDIMENT

General Considerations

In most rivers the fine fractions, namely, the silt and clay are usually uniformly distributed over the depth of a stream or nearly so whereas the coarser fractions of the suspended sediment, which are usually sand, exhibit the greatest variation in concentration from the stream bed to the water surface.

The foregoing can be explained by considering the Rouse equation, namely,

$$\frac{c}{c_a} = \left[\frac{(D-y)a}{y(D-a)} \right]^z \tag{4}$$

where

$$z = \frac{V_s}{\beta k u_*} \tag{5}$$

V_s : settling velocity of a given particle
 β and k : coefficients
 u_* : \sqrt{gRS} : friction velocity

and which gives the concentration, c , at any level, y , in terms of c_a which is the concentration at an arbitrary level, a .

Figure 4 shows a graph of the Rouse equation for several values of the exponent z . It is seen that for low values of z the concentration tends toward becoming uniform over the depth and that for large z values the concentration is small near the surface and relatively high near the bottom.

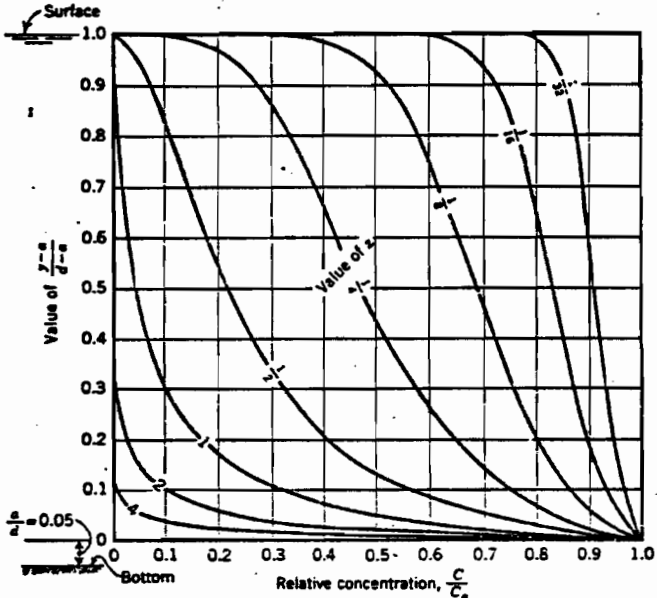

FIG. 4 —Graph of Rouse Suspended Load Distribution Equation for $a/d = 0.05$

In figure 5 it is seen that the data well fit the form of the theoretical curves for a large range of z values in different rivers of the U.S.A.

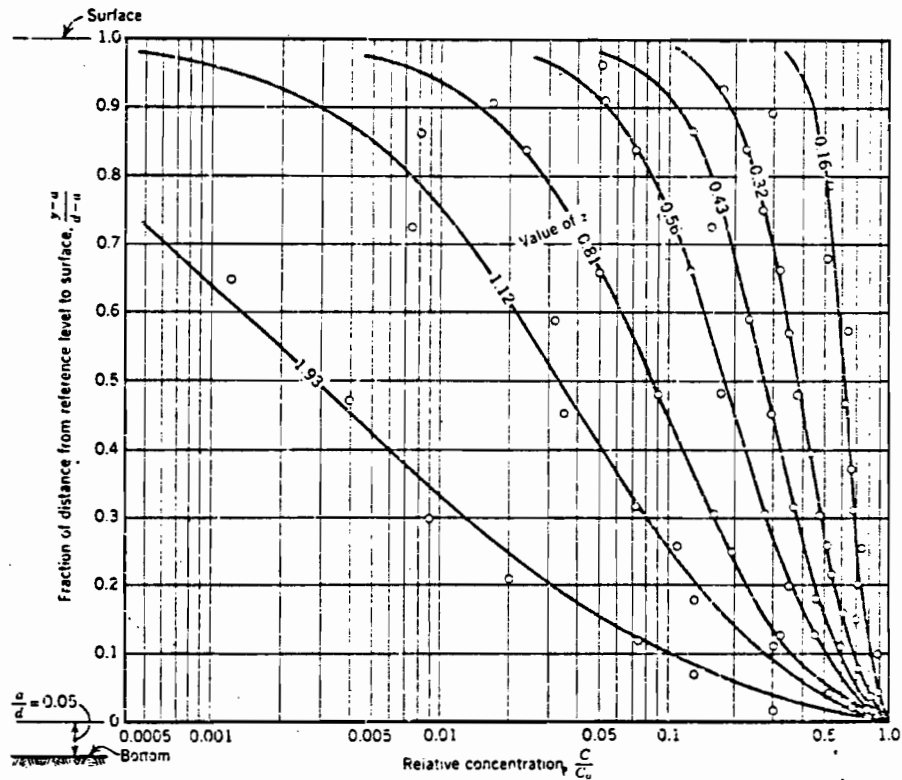

FIG. 5.—Vertical Distribution of Relative Concentration C/C_0 , Compared with Eq. 2.77 for Wide Range of Stream Size and z Values

According to equation (5) for a given flow at a given time, z is proportional to the settling velocity, v_s , so that the small grains will have small z values and be relatively uniformly distributed over the depth and the coarse grains with large z values will be concentrated near the bottom. Likewise, for a given particle the higher the shear velocity, u_* , the lesser z , therefore in the upper regime a given particle may become nearly uniformly distributed over the depth even though it was not the case in the lower regime.

The two following examples enlightens the foregoing. In fig. 6 and fig. 7, it is readily seen that changes in concentration are closely related to changes for particles which belong to the sand range (over 0.062 mm in diameter). The difference lies in the nature of the two streams, the Mississippi river is a typical large sand bed stream whereas the Rio Purco is a

steep, rapid and heavily sediment-laden stream, in the former the sand fraction of the suspended load represents a large amount of the total suspended load however in the latter the sand fraction plays a minor part and could nearly be disregarded as shown in fig. 7.

In conclusion we can say that maximum deviations from mean concentration values are found in streams where the suspended sediment consists largely of sand. In contrast minimum deviations from mean concentration values occur in stream where the suspended sediment consists largely of silt and clay. Thus, the amount of the momentary fluctuation in concentration at any depth varies with the ratio of the concentration of sand to the total concentration. Or putting it another way, the ratio of the suspended part of the bed material load to the total suspended load. This must be kept in mind when measuring suspended load....

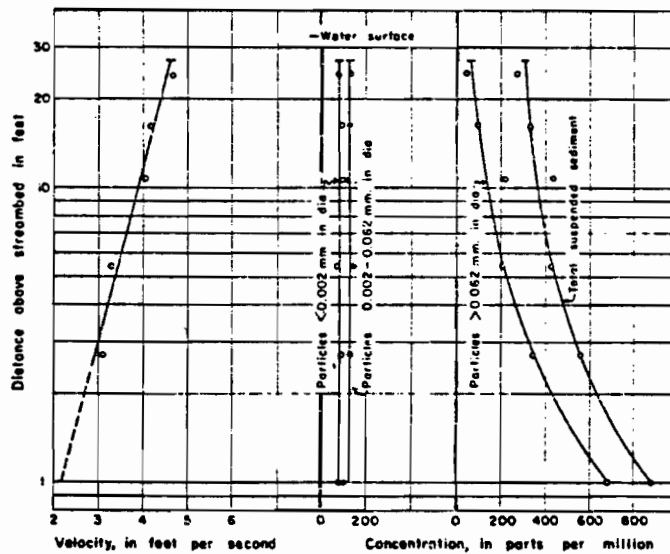
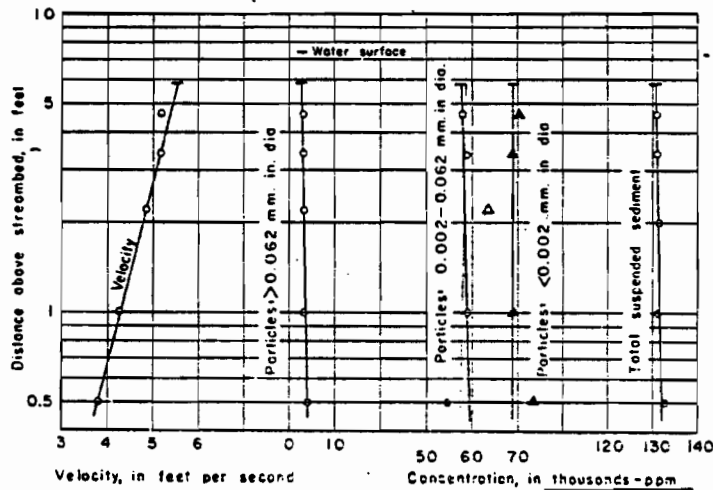

FIG. 6 —Distribution of Velocity and Suspended Sediment in Stream Vertical, Mississippi River, at St. Louis, Mo., April 24, 1956



Depth Integrating Method

Let us resume equation (3), that is,

$$Q_s = \int_0^L dx \int_a^D cudy \quad (3)$$

Our aim is to calculate the sediment discharge in weight per unit width at a given vertical. Let us denote it q_s , we have :

$$q_s = \int_a^D cudy \quad (6)$$

Let us define the mean concentration \bar{c} at a given vertical as the ratio of the sediment discharge per unit width to the water discharge per unit width at the same vertical so we have :

$$\bar{c} = \frac{\int_a^D cudy}{\int_a^D udy} \quad (7)$$

where $\int_a^D udy = q$ is the water discharge per unit width at the given vertical. So we have :

$$q_s = \bar{c}q$$

With the depth integrating method the sampler runs the vertical at a uniform speed, that is, is lowered from the surface to the bottom of the stream then raised from the bottom to the surface with a so-called transit rate which

is constant. The concentration of a sample collected in such a way represents the mean concentration \bar{c} defined by equation (6) of suspended matter at the given vertical. See Annex 1 for the proof.

Point Integrating Method

In that method samples are taken at several points in the vertical. If velocities for the same points are measured each concentration can be weighted by the corresponding velocity, that is, the product, cu , is calculated for each point and the sediment discharge is obtained by integrating over the vertical through formula 6

$$q_s = \int_a^D cudy$$

The foregoing procedure is time consuming and reserved for special studies, i.e., when concentration distribution over the vertical is needed.

To avoid measuring velocities the mean concentration in the vertical may be obtained by taking points samples which represent equal increments of depth and either keeping the same sampling time for each point sample in that case the samples may be composited into a single one whose concentration will be the mean concentration over the vertical (see Annex 2 for the proof) or recording the sampling time and using the weight of the sample collected per second to weight each sample (see Annex 2 for the proof) in that case the mean concentration is given by the following formula :

$$\bar{c} = \frac{\sum_1^n \frac{w_i}{t_i}}{\sum_1^n \frac{\text{vol}_i}{t_i}} \quad (8)$$

III. INTEGRATING SAMPLERS

The common criteria adopted for the design and construction of suspended-sediment samplers are as follows :

- To allow water to enter the sample bottle through the nozzle at the same velocity as the surrounding stream velocity
- To be streamlined so that to minimize disturbance to the flow pattern and to avoid excessive downstream drift
- To permit sampling close to the stream bed
- To be rugged and simply constructed to avoid troubles in the field

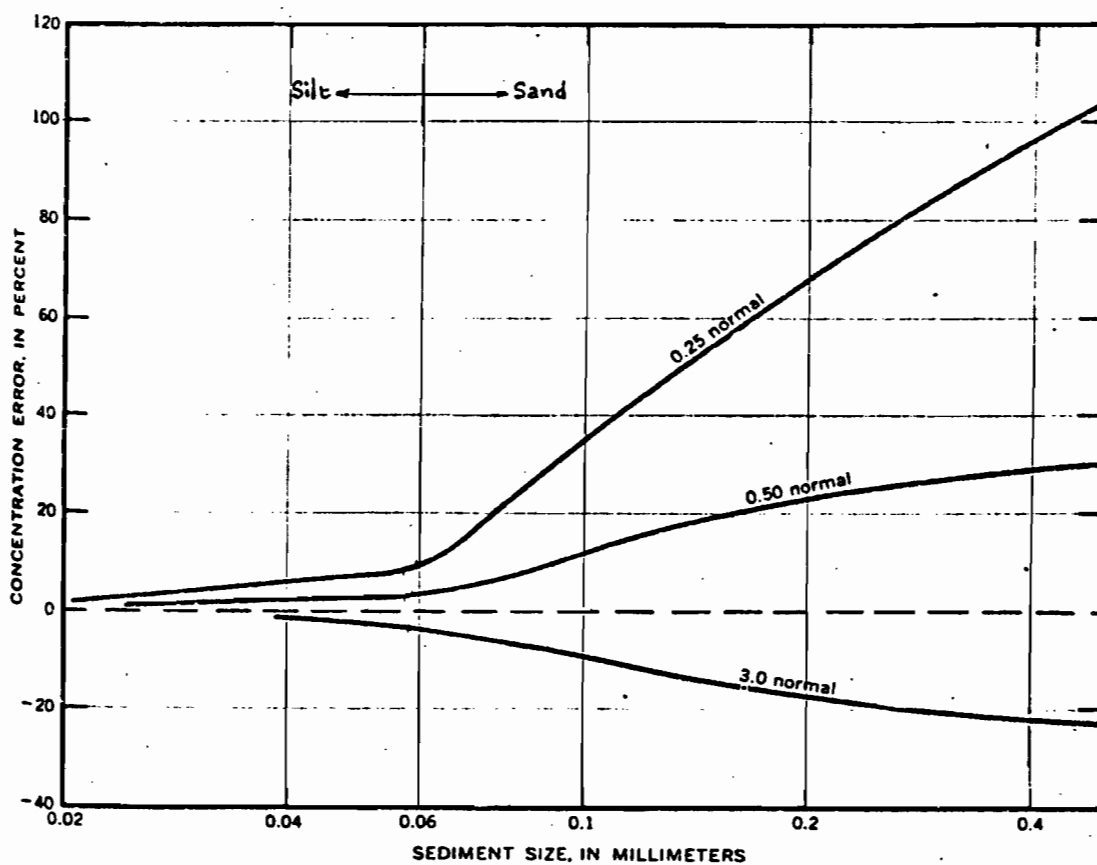

Figure 8—Error in sediment concentration for given sediment size when intake velocity is 0.25, 0.50, and 3.0 times the stream velocity. Adapted from F.I.A.S.P. (1941, p. 40).

The necessity for the first item to be respected is shown in fig. 8 which depicts the relation of sediment size to errors in concentration with respect to deviation of intake velocity. It is readily seen that :

- Fine material (< 0.062 mm) are not greatly affected when the intake velocity is different from the stream velocity
- The errors caused when intake velocities are greater than stream velocities are much less important than when the reverse occurs.

Depth Integrating Samplers

Based on a pressure equalization principle a depth-integrating sampler collects and accumulates continuously the sample as it is lowered to the bottom of the stream and raised back to the surface with a uniform transit rate, it is not necessary that transit rates be the same in both directions (see Annex 1 for the proof) but must be the same for a given direction.

Transit Rate

The sampler begins to collect the mixture when it enters the water and stops on leaving the water in order not to overflow the container inside the sampler a transit rate must be chosen taking into account the depth and the velocity prevailing at the sampled vertical.

Two factors are of importance to select the proper transit rate, namely,

- The air in the sample container is compressed by the inflowing liquid so that its pressure balances the external hydrostatic head. If the speed of lowering the sampler is such that the rate of air contraction exceeds the normal rate of liquid inflow, the actual rate of inflow will be higher than the local stream velocity and even some inflow may occur through the air exhaust.
- It was shown that when the transit rate exceeds four-tenths the mean velocity ($0.4 \bar{u}$) in the vertical the effective velocity

of the water entering the nozzle is reduced, this phenomenon being due to excessive angles between the nozzle and the approaching flow.

The foregoing is illustrated in fig. 9 where the relation between the ratio of the transit rate to the mean velocity and the depth of stream is shown.

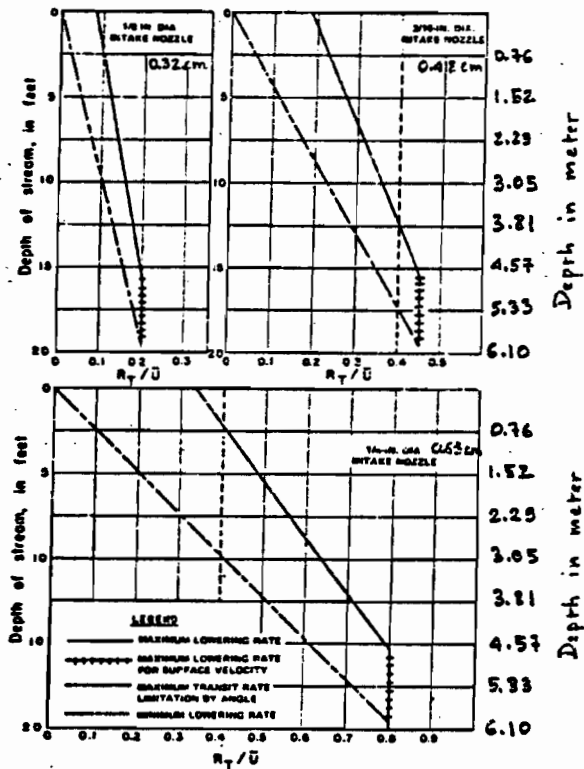

FIG. 9.—Maximum and Minimum Values of R_T/\bar{U} for Depth-Integrating Sampler with 1-pint Container (0.473 l)

It must be noted that due to the pressure equalization principle the theoretical maximum depth is limited to about 6 m regardless of the size of the sample container and the practical maximum sampling depth is about 5 m.

US Depth Integrating Samplers

DH 48 (See fig. 10)

Used for wadable streams, that is, as a practical rule when the product of depth in meter and velocity in meter per second is less than unity. It consists of a streamlined aluminum casting, 33 cm long, which partly encloses the sample container. The container, usually a round pint glass milk bottle, is sealed against a gasket in the head cavity of the sampler by a hand-operated spring-tensioned pull-rod assembly at the tail of the sampler. The sample is collected through the intake nozzle and is discharged into the bottle. The displaced air from the bottle is ejected downstream through the air exhaust alongside the head of the sampler. The sampler, including the container, weighs 2 kg. A standard stream-gaging wading rod, or other suitable handle, is threaded into the top of the sampler body for suspending the sampler. The instrument can sample to within 9 cm of the streambed. The sampler is calibrated with a nozzle that has an inside diameter of 1/4 inch (6.3 mm). However, a $\frac{3}{16}$ inch (4.8 mm) nozzle may also be used.

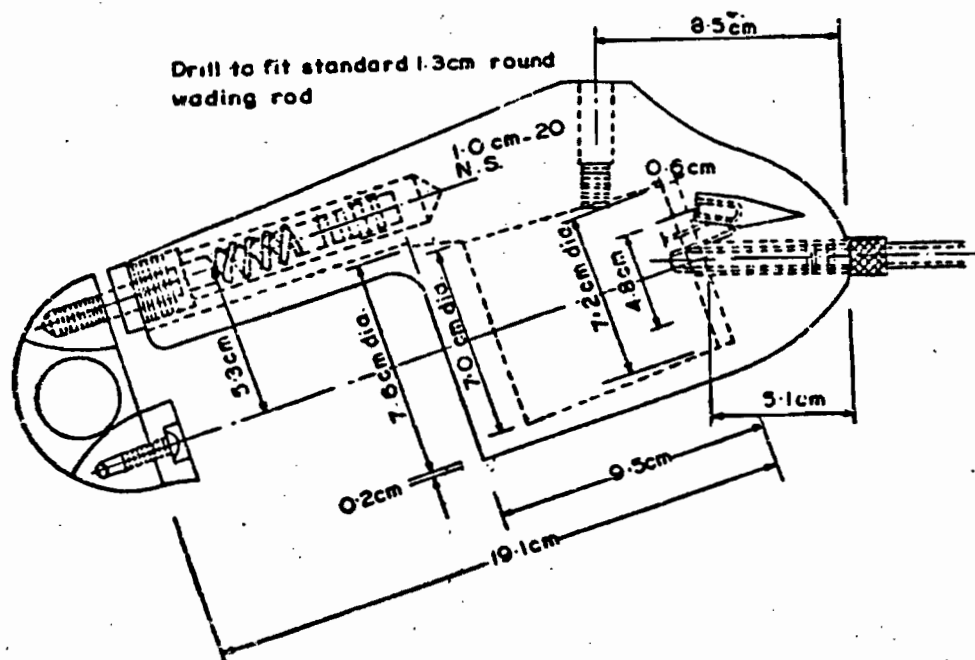

Figure 10 Depth integrating sediment sampler US DH- 48

DH 59 (See Fig. 11)

Designed to be suspended by a hand-held rope in streams too deep to be waded. It too, only partly encloses the sample container. The sampler body is 38 cm long, is made of bronze in the form of a streamlined casting, and weighs about 11 kg. Because of its light weight, it is limited in use to streams with velocities less than about 1.5 meters per second. The rope is usually cotton or nylon. Note in figure 11 that the tail vane extends below the body of the sampler and the bottle. This extension forces the sampler nozzle to orient itself into the flow before submergence. The sampler will not traverse closer than about 10 cm of the streambed. The instrument is calibrated and supplied with 1/4 inch (0.63 cm), 3/16 inch (0.48 cm), and 1/8 inch (0.32 cm) nozzles.

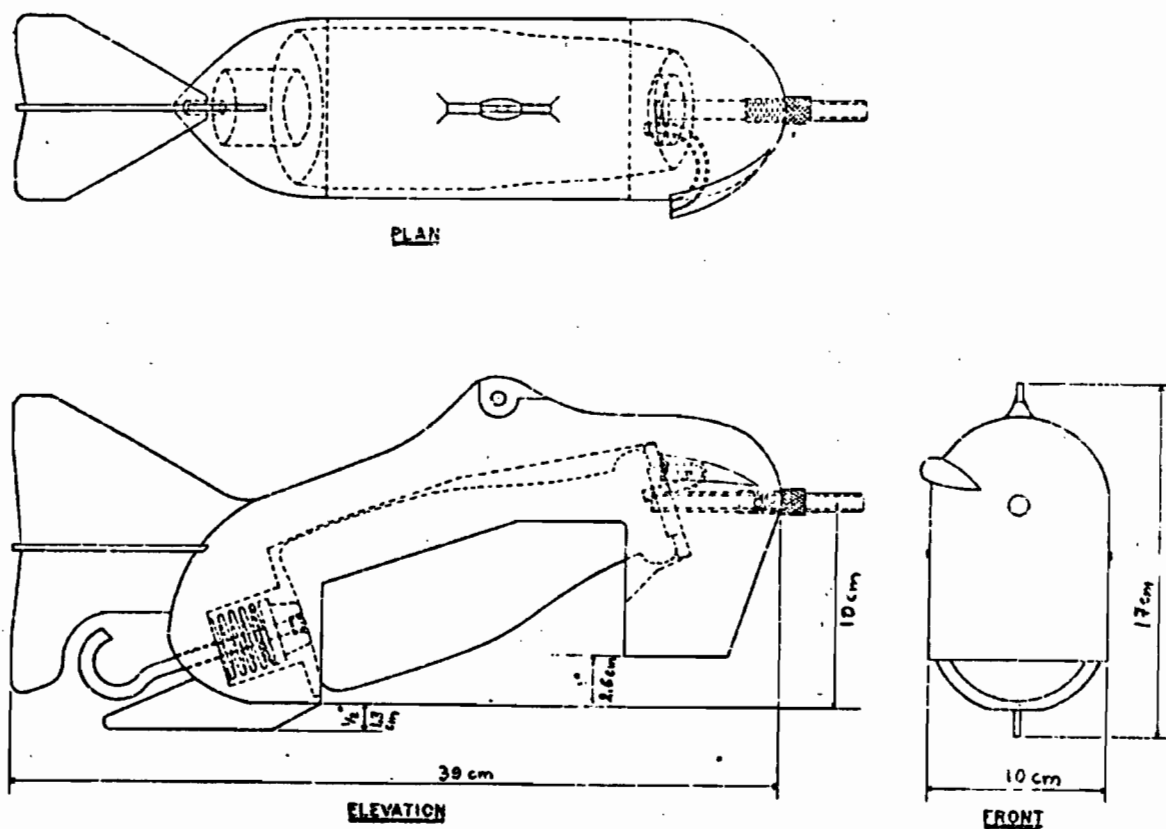

FIG. 11 —US DH-59 Depth-Integrating Suspended-Sediment Sampler (Inter-agency Committee, 1963)

D 49 Superseded by D 74

This cable suspender sampler is designed for use in streams beyond the range of the hand-operated equipment. An approximate uniform transit rate is obtained by controlling the rate of movement of the sampler by a hand-operated reel. This sampler is suitable for depth integration of streams less than 5 m in depth in which velocities preferably do not exceed 2 m/s.

US D-49 Sampler is an improved design of the D-43 Sampler. The sampler, illustrated in Figure 12 is 61 cm long, having stream-lined body and cast in one piece, weighing about 28 kg. It has a tail vane at the back and intake nozzle in the front. The sampler has an air exhaust tube and an arrangement to fit 6.25 mm, 4.75 mm and 3.18 mm diameter bore nozzles. The required size of the nozzle is selected depending upon the size and grade of sediment, stream velocity etc., after preliminary experiments.

The chamber inside the body of the sampler is fitted with a coil spring over which 1 - pint glass (milk) bottle is placed which in turn firmly forces the bottle tight against the sponge rubber sealing gasket, fitted into sampler head. The auxiliary head is provided with locking device for opening and closing the head. The sampler is provided with a free moving suspension bar attached to the body of the sampler through a pin. The detailed design of the sampler is given in Figure 12.

The sampler is lowered to the bottom of the stream vertically down and raised again to the surface at uniform rate. Sampling period is so adjusted that the container is filled to about 9/10 of its capacity in these two journeys. If the container becomes completely filled, during sampling operation, the sample is not representative and must be discarded. The maximum and minimum transit rates for round-trip depth integration with 3.2, 4.8 and 6.3 mm nozzles are shown in Figure 9.

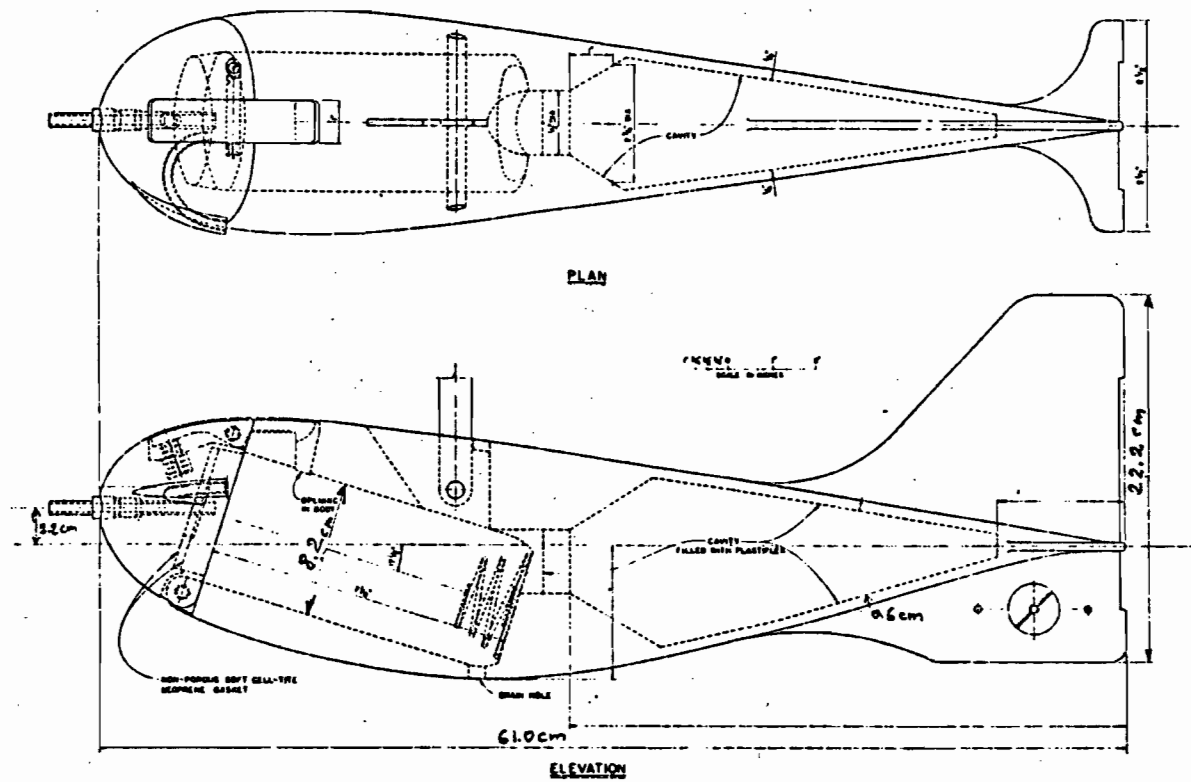

FIG. 12.—US D-49 Depth-Integrating Suspended-Sediment Sampler (Interagency Committee, 1952)

Point Integrating Samplers

Point-integrating samplers are more versatile than depth integrating types since they not only may be used as depth-integrating samplers over a part of the whole vertical but to collect a sample at any desired depth as well. They are used for depth or point-integration in streams too deep (more than 15 feet) or too swift to sample in a round-trip integration without overfilling the bottle at the maximum allowable transit rate. The intake and exhaust passages are controlled by a valve which is operated from the surface. The body of the sampler contains an air chamber to equalize the air pressure at the sampling point in order to avoid the inrush which would otherwise occur when opening the intake and air exhaust below the surface.

In depth integration sampling can start any point and continue in either an upward or downward direction for a maximum vertical distance of about 9 m.

To calculate the mean concentration over a vertical see Annex 2.

Remark : Due to their weight, point-integrating samplers require heavy equipment to be operated sounding reels, bridge cranes, etc...

US P-61 Sampler

The design of the US P-61 Sampler is illustrated diagrammatically in Figure 13. It is a cast Bronze Sampler, 71 cm long. It is streamlined and has tail vanes to orient the sampler so that the intake nozzle in the head points directly into the approaching flow. The sample head is hinged to provide access to the round pint milk bottle sample container. The air chamber in the body is connected to the cavity in the sampler head and head cavity is connected through the valve to the sampler bottle; the intake and air exhaust passages are closed. When the head is closed on the body, the sampler container is sealed in place when the electric current is passed, the solenoid

turns a rotary valve through an angle of 45° and the valve is in sampling position. The intake and air exhaust passages are open; but the connection from the bottle to the head cavity is closed. The resistance of the solenoid is about 24 ohms and minimum current of one ampere is supplied to move the valve in sampling position. A current supply of 48 volt is needed for sampling up to 30.48 m depth.

This sampler can be used for depth-integration as well as for point-integration in the stream depths of about 46 m. The capacity of the pressure equalising chamber in US P-61 Sampler is improved. It permits sampling to a maximum depth of about 50 m - 55 m. In streams, where depths are about 5.5 m and velocities are moderate, samples of suspended sediment can be collected by depth-integrating method i.e., the sampler valve is held open by electrical mechanism, both during lowering as well as raising the sampler to the water surface. In the streams where depths are greater than 5 m or are up to 9 m and velocities are high, the sampler is used as depth integrating in one direction only i.e., from the bottom of the stream to the surface.

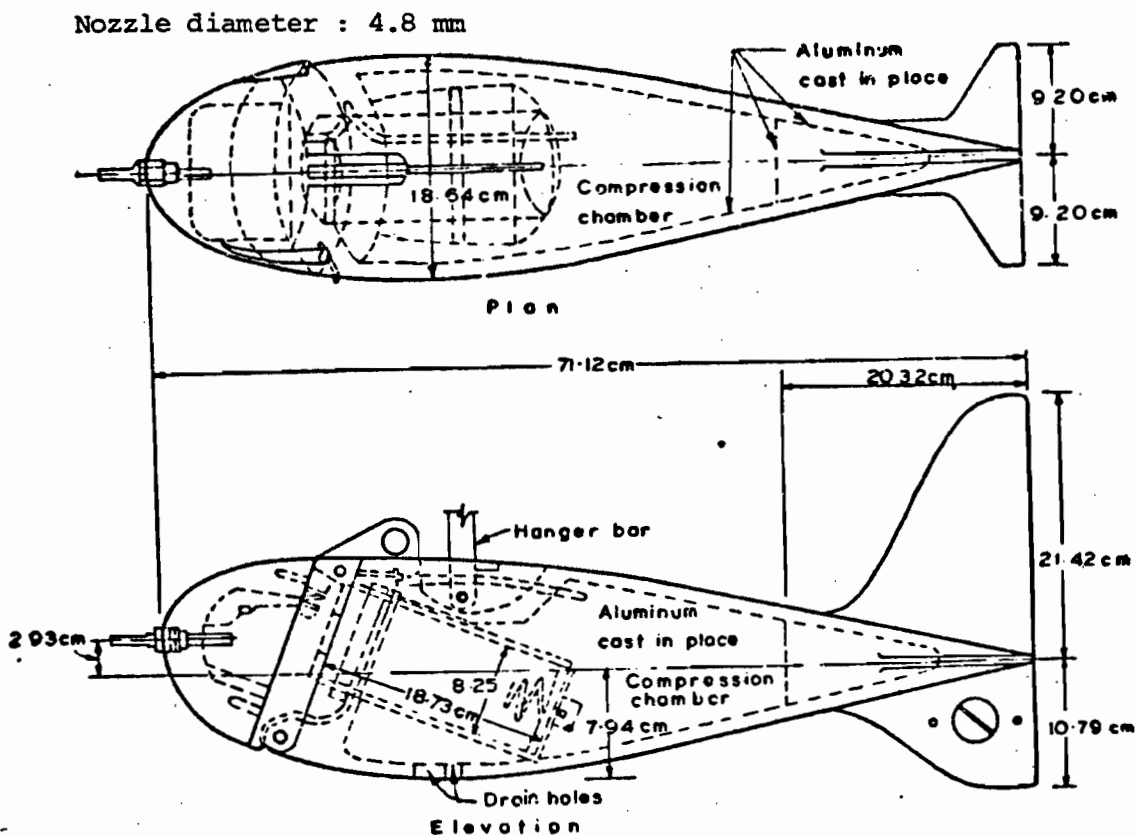

Figure 13: Point-integrating suspended-sediment sampler U.S.P. 61

US P-63 Sampler

In streams which are too deep or flow too fast, another Sampler US P-63 of larger size, capacity and weight is used. US P-63 is a 91 kg electrically operated suspended sediment sampler. It is a cast Bronze Sampler, 86 cm long. It is streamlined and has tail vanes to orient the sampler so that the intake nozzle points directly into the approaching flow (Figure 14). The valve mechanism and operation of the US P-63 Sampler is the same as that of US P-61 Sampler. In this sampler, an adapter can be fitted in the container-shell so that a quart-sized bottle can be used instead of a pint milk bottle. The maximum depth to which sampling can be done with a quart sample container is about 55 m as against 36 m with a pint container. There is a pressure chamber in the sampler body. The air in the pressure chamber is at the static pressure corresponding to the depth of submergence. About 48 volts of direct current is required. If suspension cable is longer than 30 m, a higher voltage may be desired.

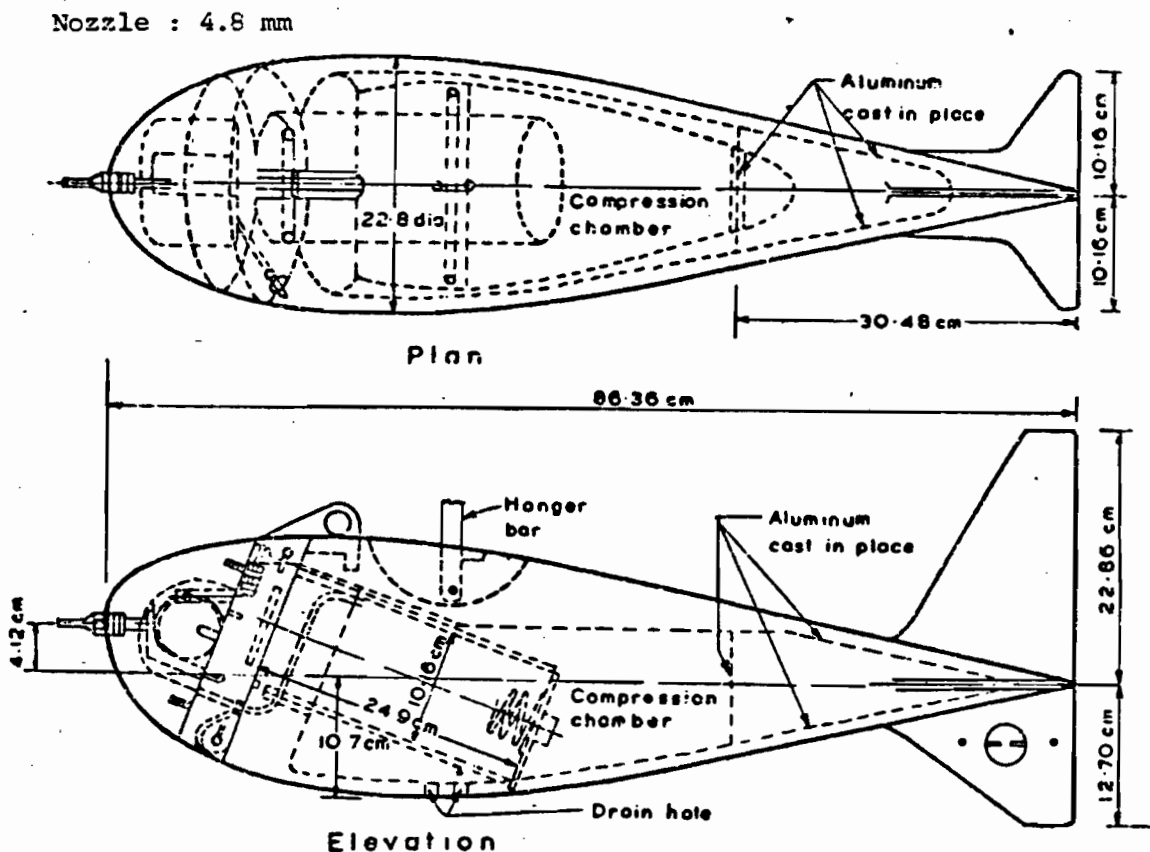

Figure 14 : Point-integrating suspended-sediment sampler U.S. P. 63

Neyrpic Sediment Sampling or "Turbidisonde 80"

This is a point-integrating sampler somewhat different in its principle since to prevent the water-sediment mixture from entering the container a continuous flow of compressed air is provided through a special hollow cable 8.5 mm in diameter from a high pressure container or air compressor at the surface. During the sampling period, the air is released from the container by two venturi tubes at a rate controlled by the stream velocity. Likewise the P 61 and P 63 it can be used to collect either depth or point-integrated samples.

The sampler shown in fig. 15 and 16 weigh 93 kg and utilizes a container with a 800 cm³ capacity, it can be used for velocities up to 3.8 m/sec. The instrument is fitted with a standard nozzle tube of 6.35 mm in diameter. The body of the instrument is balanced by the tail provided with stabilizing fins.

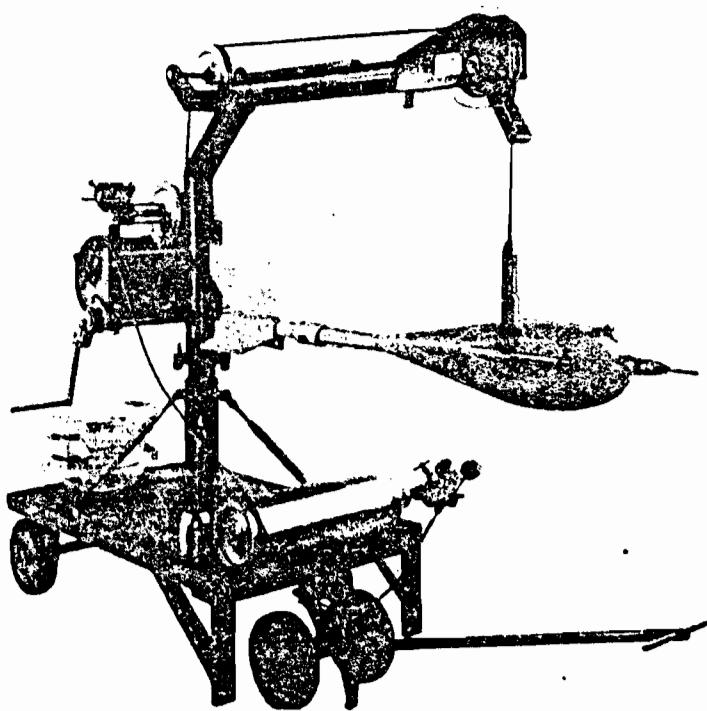

Photo Neyrpic

Fig. 15. Turbidisonde Neyrpic .

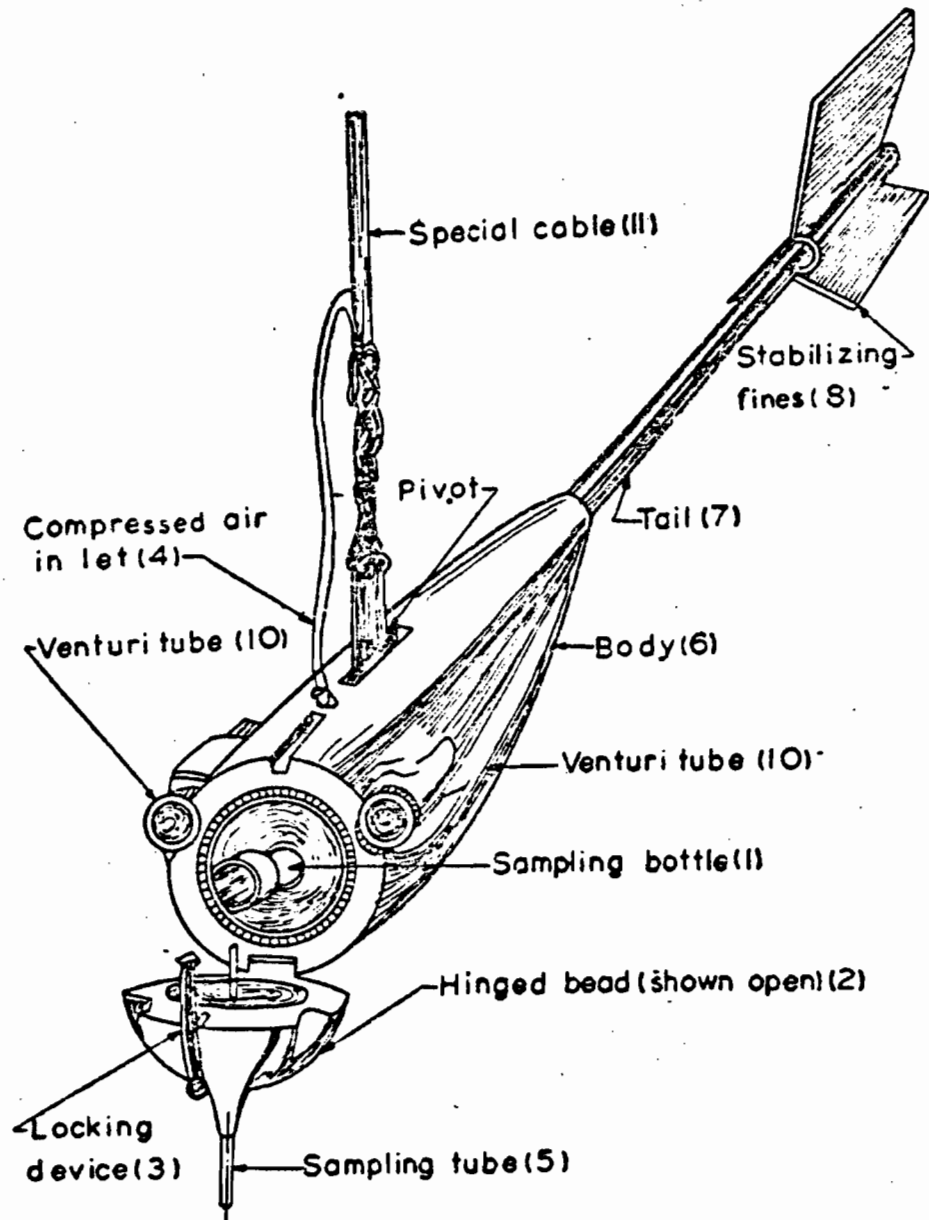
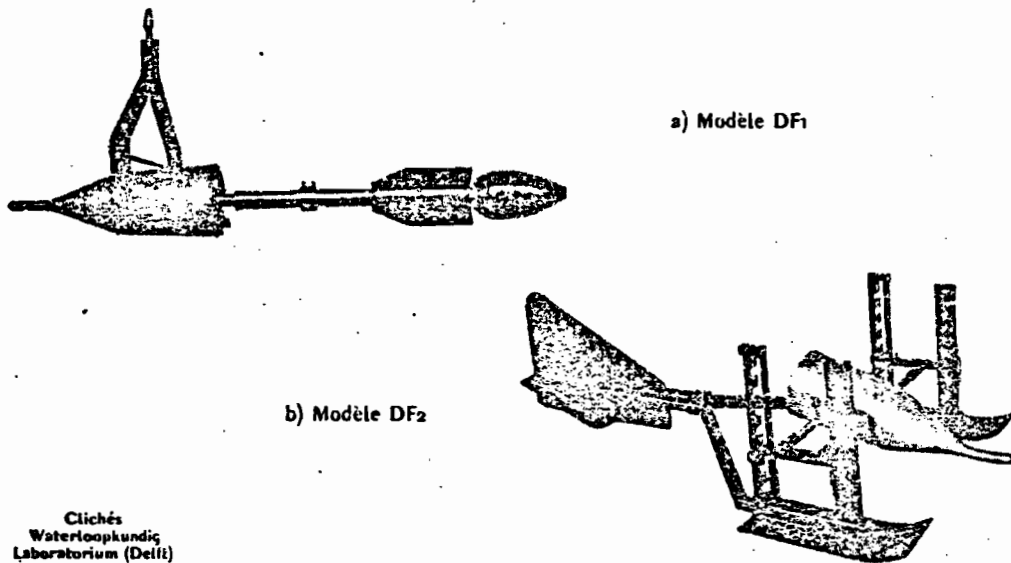

Figure 16: Turbidisonde Nevripic-L 80 suspended load sampler

Delft Bottle

When the suspended load is made up of sand-sized particles or one is interested only in the coarse material load the Delft bottle can be used.

The principle is completely different, instead of collecting a sample of water-sediment mixture the sampler collects the suspended load directly. Due to a sharp velocity decrease the sand sized particles settle out inside the sampler and the water leaves the sampler. The sampler can be let under the surface for a long period of time so that to collect a large volume of suspended material.



Clichés
Waterloopkundig
Laboratorium (Delft)

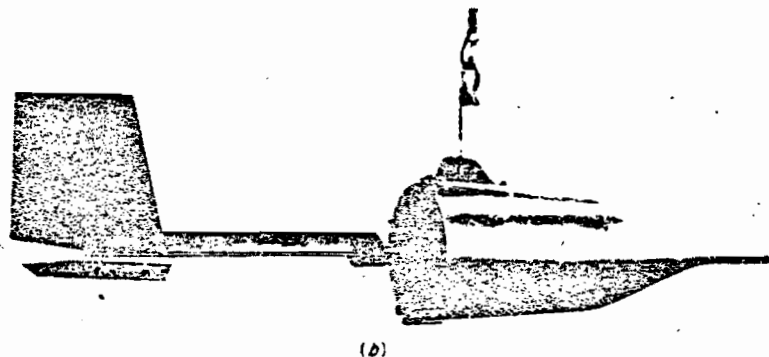
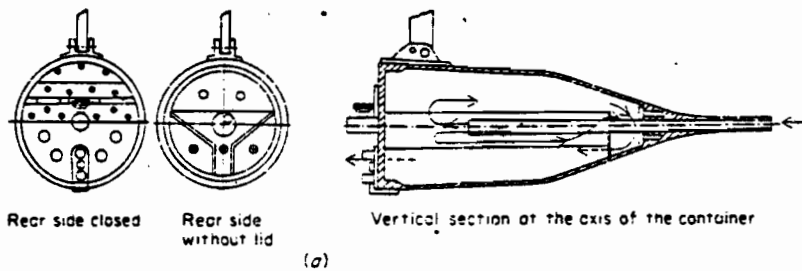

Fig. 17 The Delft bottle. (a) Schematic sketch, (b) suspended on a cable.

IV. PRACTICAL OBSERVATIONS ABOUT THE USE OF THE U.S. SILT SAMPLERS

As to practical ways to handle the equipment nothing better than quoting a leading specialist GUY in "Field Methods for Measurement of Fluvial Sediment".

Transit Rate

Additional explanation and qualifications with respect to the transit rate for suspended-sediment sampling include :

1. For cable-suspended samplers, the instantaneous actual transit may differ considerably from the computed rate, R_t , if \bar{U} exceeds about 1.8 m/s and if the sampler is suspended from more than 6 m above the water surface. Under such conditions, the sampler is dragged downstream and the indicated depth is greater than the true depth. Corrections for indicated depth are given by Buchanan and Somers (1969, p. 50-56) for various angles and lengths of sounding line used for suspension of a weight in deep, swift water. The corrected depth would then be used to enter in figure 18 to determine the needed transit rate.
2. The allowable R_t may be greater than $0.4 \bar{U}$ and sampling depth thereby increased if the sampler is cable suspended and capable of tilting itself somewhat in the direction of vertical movement. On the other hand, where the sampler cannot tilt, where the velocity at the bottom of the vertical is much less than \bar{U} , and where there is a heavy concentration of suspended sand near the bed, the use of a R_t value that nears this limitation may cause R_t to approach or even exceed the actual u near the bed and thus cause an excessive error in the intake of sand particles. The approach-angle theoretical depth limits will of course be less if either the downward or the upward transit rates, R_{td} or R_{tu} are different from R_t .
3. The indicated lower limit, because of air compression, is based on the assumption of a uniform velocity distribution in the vertical. Where the velocity is considerably greater than the mean in the upper part of the vertical, the lower limit can be increased somewhat. The air compression lower limit can also be increased by using a downward transit rate, R_{td} , that is less than the indicated R_t and then to compensate for the extra filling of the bottle on the downward trip by using an equally greater upward transit rate, R_{tu} . For example, 6.00 m may be sampled with an 1/8 inch nozzle if where $R_t = 0.37$ is indicated (for $\bar{U} = 1.52$ m/s) by using $R_{td} = 0.27$ and $R_{tu} = 0.46$ m/s.

4. Because of possible greater deviation from the ideal relation of intake velocity to stream velocity of 1.0, the 1/8-inch nozzle should not be used if there are significant quantities of sand larger than 0.25 mm in suspension. The 1/8-inch nozzle is also less reliable than the larger nozzles where small roots and other organic fibers are suspended in the flow.
5. In the event that the sampler accommodates a quart-sized bottle, half the indicated R_t can be used. With the quart-sized bottle, the depth limit for the 1/4-inch nozzle, where $R_t = 0.4 \bar{U}$, be computed to 5.0 m. In practice, however, the 4.6 m limitation because of air compression should apply unless the exceptions indicated in 3 (above) can be applied.

An alinement graph is given in Figure 18 for which both transit rate and transit time can be determined given the depth and the mean velocity of the vertical, according to the nozzle diameter and for a round trip. The example on the graph shows that a vertical 2.35 m deep flowing at 1.20 m/s requires a transit rate of 0.26 m/s if a 0.48 cm nozzle is used and 0.46 m/s if a 0.63 cm nozzle is used. The total transit time for each nozzle is 11 and 18 seconds respectively. Figure 19 gives the transit time or filling time with respect to the mean velocity for each nozzle.

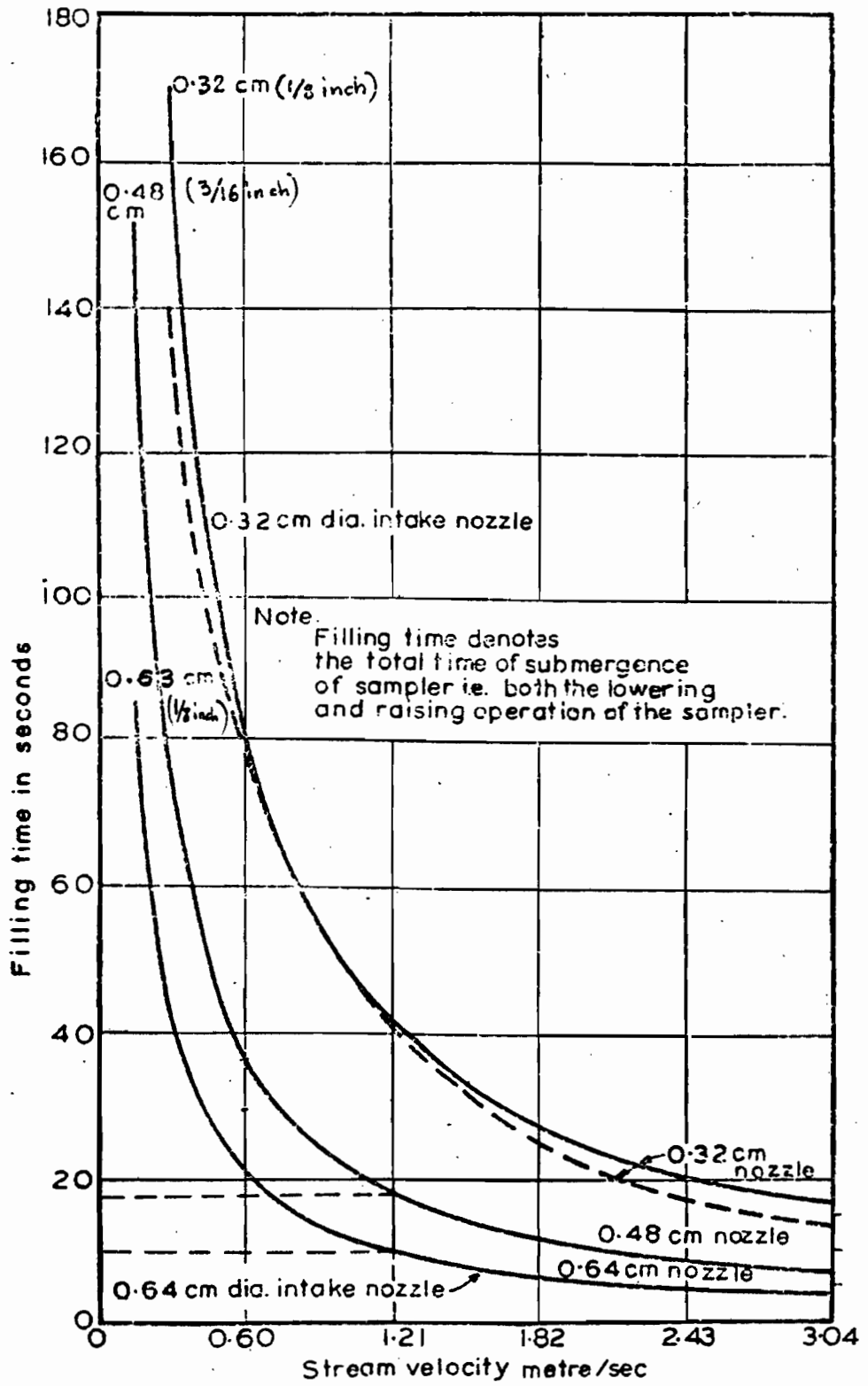

Volume=395 cc sampling ratio=1:0

Figure 19: Filling time for pint sample bottle suspended sediment sampler U.S.D. 49, DH 48, DH 59.

Nozzles

Each suspended-sediment sampler is equipped with a set of nozzles that may have been calibrated specifically for the particular sampler, but more than likely, the given calibration was for a particular series of samplers having similar physical characteristics. For the individually calibrated units, almost one-third of the purchase price of the sampler represents calibration costs. These nozzles are cut and shaped externally and internally to insure that the velocity of water after entering the nozzle is within 3 to 5 percent of the immediate stream velocity. It has been found that a deviation in intake velocity from the stream velocity at the sampling point causes error in the concentration of the sample, especially for the sand-sized particles (fig. 8). For example, a plus 10 percent error in sediment concentration is likely for particles of sediment 0.45 mm in diameter, when the intake velocity is 25 percent less than stream velocity (F.I.A.S.P., 1941, p. 38-41).

Because each of the sampler nozzles is calibrated for its particular sampler or series of samplers, it must be emphasized that a nozzle from one series of samplers cannot be properly used in another series of samplers. The only exceptions are the recent P-61 and P-63 series which use the same nozzles.

The reasons for the differences between the nozzles of different series are : (1) the length of flow paths for water and air are different, and it results in differences of flow resistance, and (2) the differential heads between the nozzle entrance and the air exhaust are different. Thus, interchanging nozzles between sampler series results generally in an incorrect intake velocity and thus incorrect sediment concentration and particle size distribution in the sample. Therefore, when a nozzle is damaged, be certain to use a correct replacement nozzle.

If extra nozzles are needed for a specific sampler or series, they can be obtained by writing to the F.I.A.S.P. (address can be obtained from the latest inter-agency report) and including the sampler number. If exhaust tubes on the samplers become damaged or deformed, the entire sampler should be sent to the F.I.A.S.P. for repair and recalibration.

Except for the DH-48, three different size nozzles, 1/4-inch, 3/16-inch, and 1/8-inch, may be used to take samples with the depth-integrating samplers. The DH-48 was designed for use in slow wadable streams, and therefore, a 1/8-inch nozzle has never been calibrated for this instrument. Note that just because a nozzle may physically fit a sampler, it is not necessarily the correct one. For example, it is possible, but incorrect, to use the same nozzle in a D-43, a DH-48, a DH-59, or a D-49.

The reason for different size nozzles is that stream velocities and depths occur which will cause the sample bottle to overflow for a specific transit rate when using the largest nozzle. More specifically, the maximum theoretical sampling depths for round trip integration are about 2.4, 4.3, and 4.6 m. for the 1/4-, 3/16-, and 1/8-inch nozzles, respectively, and twice these depths for one way integration when the ordinary pint sample bottle is used. Therefore, in order to reduce the quantity of sample entering the bottle, the next smaller nozzle is used with the view that the best sample is obtained with the largest nozzle which can be used in a given situation. The larger the nozzle, the smaller the chance of excluding large sand particles which may be in suspension. It should be pointed out that possible errors caused by using too small a nozzle are usually minor when dealing with fine material (0.062 mm) but tend to increase in importance with increasing particle size. Also it has been found through experience that the small nozzles plug with organic material, sediment, and ice particles easier than the large ones. This means that problems with nozzles can even exist with streams transporting mostly fine material.

Point-integrating samplers are supplied only with a 3/16-inch nozzle because the opening through the valve mechanism is only three-sixteenths of an inch (4.8 mm).

Gaskets

Of equal importance to the correct nozzle in the instrument is the necessity to use the proper gasket to seal the bottle mouth sufficiently. The gasket for this purpose is usually made of a spongelike neoprene material which deteriorates somewhat with use and time. Thus, to avoid leakage around the mouth of the sample bottle which will yield bad samples, it is best to check the gasket occasionally. It is possible that gaskets can be misaligned or even lost during transportation, or while changing bottles when taking samples.

To check the gasket for adequate seal, insert a bottle in the proper position in the sampler, then while the air-exhaust port is closed with a finger, blow through the sampler nozzle. If air escapes around the bottle mouth, the gasket needs replacing, or perhaps the spring loaded foot holding the bottle in place is not working properly. Each sampler series uses a different size or shaped gasket, so it is necessary to have spares of each series on hand. Appropriate gaskets may be obtained from the F.I.A.S.P.

Bottles

At present, most districts use the standard pint-sized glass milk bottles for which the instruments were designed. Each bottle is partially etched to provide a writing surface on which to record pertinent information concerning each sample. (See fig. 20). The writing surface should accommodate marking with a medium soft blue or black pencil of sufficient durability to withstand handling and yet be easily removed when the bottles are cleaned. The Ohio District (P. W. Anttila, written commun., August 1968) uses a compound commercially called "Activated Jack Frost" to provide the writing surface on glass bottles. It can be purchased from McKay Chemical Company, 880 Pacific Street, Brooklyn, N.Y. 11238. Hydrofluoric acid has been used for this purpose, but is less desirable because it must be handled carefully and stored in a polyethylene container. "Activated Jack Frost" can be stored in a metal container.

Some districts use plain bottles and attach tags for recording purposes. The required information can also be recorded on the bottle cap if there are no alternatives, but this should be avoided because of the small writing space and because of the possibility of putting the cap on the wrong bottle.

A trial use of plastic bottles is underway (1968) in Alaska. These should eliminate such problems as etching, breakage from handling and freezing, and most important reduce weight and transport costs. The ideal plastic bottle should be disposable to avoid cleaning costs. The ideal arrangement would also involve the use of a collapsible bottle so that the problem of air compressibility during depth integration could be avoided.

Bottles are usually stored and transported in wire, wooden, or fiber-board cases holding 20 to 30 bottles each. However, in the field, it is desirable to use a small bottle carrier which holds six, eight, or 10 bottles. This eliminates the need to handle the heavier 20- or 30-bottle cases while

making a measurement and provides a near, convenient, and relatively safe place to set the bottles. In making wading measurements both hands can be freed to operate the sampler if the bottle carrier is suspended from the shoulder with a strap or rope.

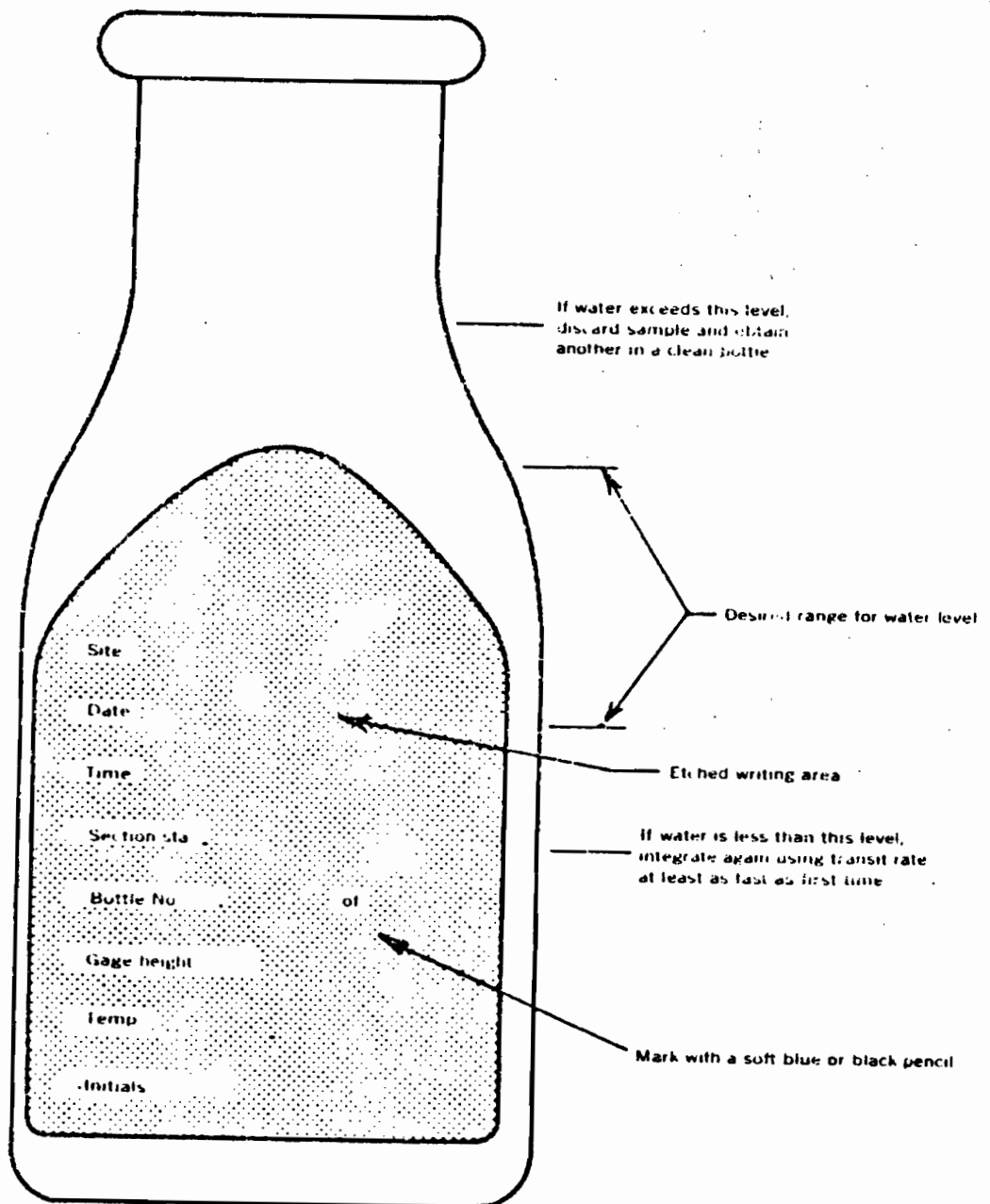

Figure 20. Diagram of sample bottle showing desired water levels and essential recorded information. Sometimes other information concerning type of sampler used, the section location, and stream conditions should also be noted.

V. LATERAL DISTRIBUTION OF SUSPENDED SEDIMENT

In the same way as for the vertical distribution of suspended sediment and as far as the site chosen for making the measurements fulfills certain conditions we can say with GUY "All or mainly all the concentration variation at different verticals across the stream will be the result of sand-sized material and finer sediments are uniformly disposed throughout the section unless the section is close to a tributary and mixing is not complete."

The mean concentration for the entire cross section is denoted \bar{C} and defined as the ratio of the suspended sediment discharge to the water discharge, that is :

$$\bar{C} = \frac{\iint_A c u dx dy}{\iint_A u dx dy} = \frac{Q_s}{Q} \quad (9)$$

Let us assume that given a gauge height in a stream the water discharge is known, in that case if there is a means to obtain the mean concentration, the suspended sediment discharge will be the product of the mean concentration and the water discharge since from (9) we get :

$$Q_s = Q \bar{C} \quad (10)$$

Two methods are of current use to determine the mean concentration, namely, the E.D.I. method and the E.T.R. method. Before describing them it is logical to give some informations about the "site selection". Since measuring in a poor site will yield mediocre results whatever the method, the number of verticals required to obtain good results depends on the selected site and so is also discussed.

Site Selection

As previously done, we draw heavily on Guy's work.

The sediment sampling techniques to be used in a given situation will depend not only on the data needs, but also on the nature of the flow and other conditions at the site to be used for making the measurements. The site must often be located at a specific gaging station; but sometimes, especially for large basins that have a number of gaging stations, there may be some choice as to location. Where there is a choice between measurement sites, then an analysis should be made of the data needs and program objectives to maximize the returns in consideration of the relative costs, data accuracy, and the physical limitations. The perfect site is rarely available, and therefore, it is necessary to recognize as many limitations as possible and then to build a program that will minimize the disadvantages and maximize the advantages.

As indicated, the site should be at or near a gaging station because of the obvious relation of sediment movement to the flow of the stream. If the sediment-measuring site is more than a few hundred feet from the water-stage recorder, then it may be desirable to install a simple non-recording stage indicator at the site so that a correlation of the flow conditions between the sediment and the distant water-measuring sites can be developed. The obvious difficulties with inflow between the sites from small tributaries should also be avoided, if possible.

The normal stage-discharge relation at a gaging station upstream from the confluence with another stream may be disturbed at times because of unusual water-surface slope conditions resulting from partial backwater effects. The unusual slope condition will likewise affect the normal movement of sediment and thereby require many additional sediment measurements.

A sediment-measuring site downstream from the confluence of two streams may also require extra sediment measurements. The downstream site may be adequate for water-discharge measurement because the lateral water surface across the stream section is stable regardless of the differences between the quantity of flow for the two tributaries. Though the surface level of the flow may be stable, the flow from the two tributaries does not readily mix, and the sediment may be moving almost as two streams in proportion to the inflow from the two tributaries. As indicated in Book 3, Chapter C1, "Fluvial Sediment Concepts" (Guy, 1970, 0.24), the distance downstream from a confluence for complete

mixing depends on the stream velocity, depth, and mixing width. If the flow at a sediment-measuring site is not mixed, then extra samples will be required on a continuing basis because the relative flow quantity and sediment concentration from the two tributaries will change with time.

Aside from the confluence or tributary problem, the type of cross section for both flow in the channel and on the flood plain may be important to the ease with which data can be obtained and to the quality of the samples. The ratio of the suspended to total load and its variation with time can be greatly affected by the width-depth ratio, especially for sand-bed streams. For sites where the data are expected to be correlated with channel properties and the landforms of the region, a normal or average section should be used. When a fixed-routine sampling installation is used, a measuring section at a bend may provide a more stable thalweg and hence a more uniform adjustment coefficient with respect to time than one at a crossover. Sites in areas of active bank erosion should be avoided, however.

By economic necessity, most sediment-measuring sites are at highway bridges. These bridges are often either constructed so that they restrict the flow width, or they may be located at a section where the channel is naturally restricted in width. Figure 21 (Culbertson, Young and Brice, 1967) illustrated the conditions at several kinds of natural and artificially induced flow constrictions. As expected, the sand-bed type of stream causes the most serious flow problems with respect to scour in the vicinity of such constrictions. Even if the bridge abutments do not interfere with the natural width of the stream, it may be supported by several midstream piers that can interfere with the stream-flow lines and thereby reduce the effective cross-sectional area. As indicated in figure 21, midstream piers can catch debris and thereby seriously interfere with effective sediment sampling.

Because sediment samples must be obtained more frequently during floods, it is imperative that a site be selected where it is feasible to obtain data during times of flooding. That is, particular attention should be given to the ease of access to the water-stage recorder and a usable bridge or cable during a flood. Such access takes on much more importance when a sediment station is involved than when the interest is only for a water-discharge station. Also, because of the need to collect samples frequently during floods, many of which occur at night, sites accessible only by poorly maintained back roads or trails should be avoided, if possible. Sometimes the choice of a sediment-measuring site may be determined by the availability of a suitable observer to collect the routine samples.

In choosing a sediment-measurement site, it should be emphasized that samples should be collected at the same cross section throughout the period of record, if possible. This is not to say that separate sections may not be used during the low-water wading stage and the higher stages that require the use of a bridge or cable-way. In this connection, sites should be avoided where highway or channel realignment or other construction is anticipated during the period of record. It should be emphasized that good photographs of proposed or selected sediment-measuring sites are necessary to help document such features as channel alignment, water surface conditions at various stages, composition of bed and bank material (at low flow), and natural or man-made features which could affect the water discharge and (or) sediment-discharge relations. Such pictures are particularly useful when deciding on alternatives among sites and in later consideration of environmental changes at the site(s).

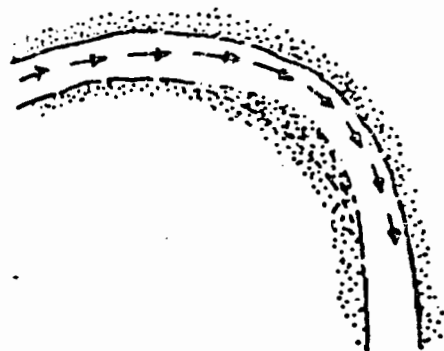

A. NATURAL CONSTRICTION OF CHANNEL AT BEND

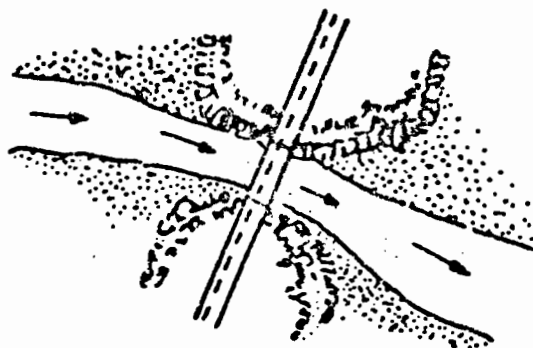

B. NATURAL CONSTRICTION OF CHANNEL BY RESISTANT BEDROCK

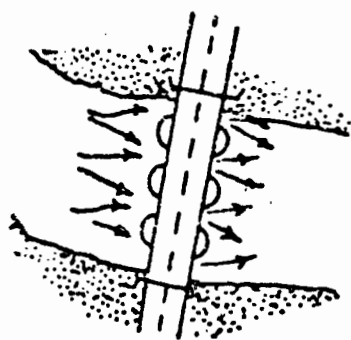

C. CONSTRICTION OF CHANNEL BY MASSIVE PIERS

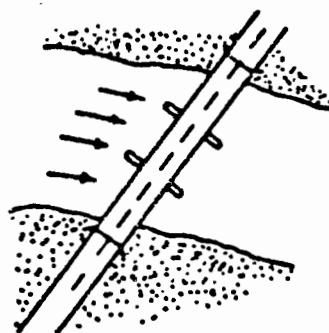

D. EFFECTIVE CONSTRICTION OF CHANNEL BY LONG SKEWED PIERS

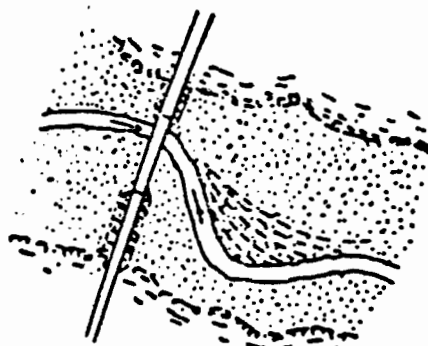

E. CONSTRICTION OF FLOOD PLAIN BY EMBANKMENTS

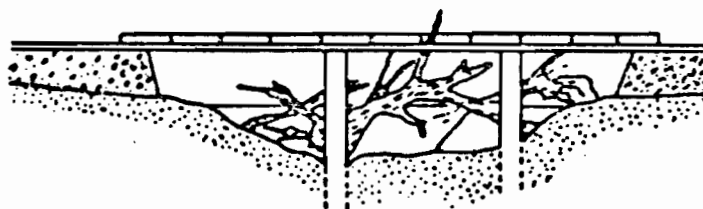

F. CONSTRICTION OF FLOW BY ACCUMULATION OF DEBRIS

Fig. 21—Examples of natural and artificially induced streamflow constrictions encountered at sediment-measurement sites. From Culbertson, Young, and Brice (1967, p. 23).

Number of Sampling Verticals

Several factors intervene to select the number of verticals:

- Percentage of sand-sized particles in the suspended load (related to bed material)
- Shape of the cross section (regular or irregular) width etc...
- Lateral velocity distribution
- Acceptable relative standard error

A useful criterion is the $\frac{v^2}{D}$ quantity which was found to be closely related to the variability of concentration (sand-sized particles) for different sampling verticals, V being the mean velocity and D the depth at the vertical.

In figure 22 a nomograph is presented that indicates the number of sampling verticals required for a desired maximum acceptable relative standard error based on the percentage of sand and the compound ratio

$$\frac{v^2/D \text{ (max)}}{\bar{v}^2/\bar{D}} \text{ called the } \frac{v^2}{D} \text{ index}$$

where $\frac{v^2}{D} \text{ (max)}$ is the $\frac{v^2}{D}$ index at the vertical for which it is maximum

and $\frac{\bar{v}^2}{\bar{D}}$ is the ratio of the mean stream velocity to the mean depth.

The mean velocity and mean depth are available from water-discharge measurements.

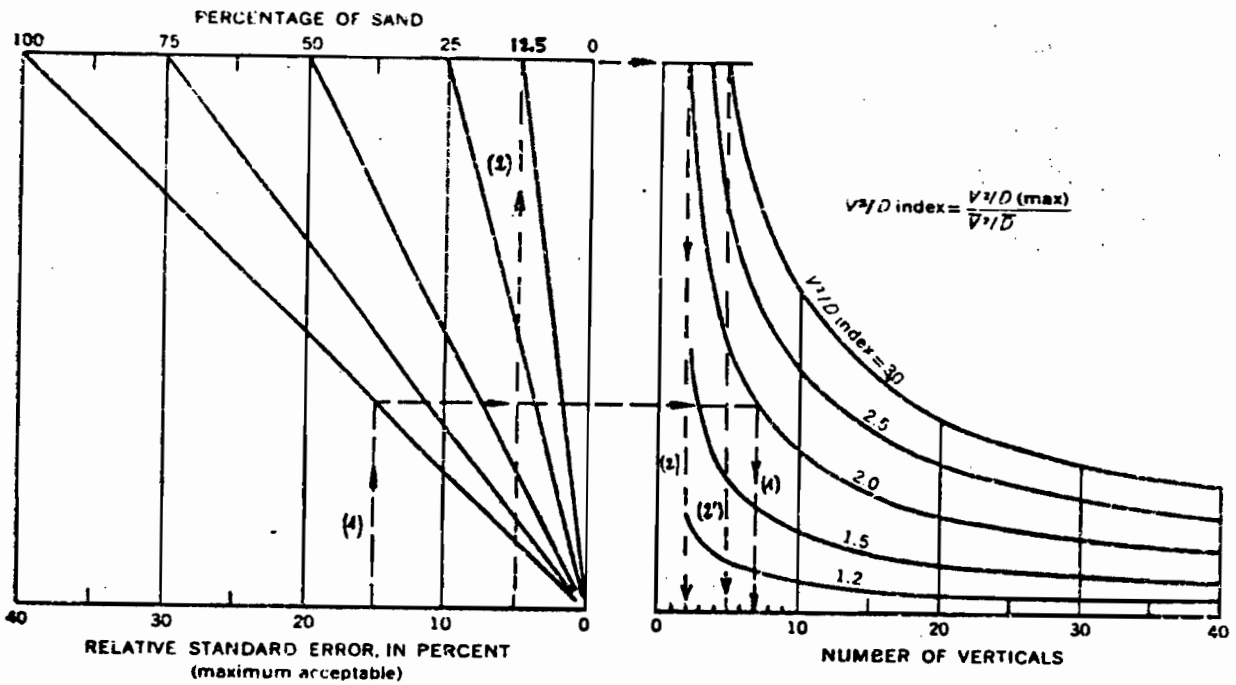

Figure 22 -Nomograph to determine the number of sampling verticals required to obtain results within an acceptable relative standard error based on the percentage of sand in the sample and the V^2/D index. Best results are obtained when V is between 2 and 5 fps and D is greater than 1.5 feet.

Illustrated in figure 22 it is seen in the first example that given a percentage of sand of 100% and a $\frac{V^2}{D}$ index of 2 for a relative standard error of 15% the number of verticals is seven. In the second example the percentage of sand is 12.5% the $\frac{V^2}{D}$ is 2 and the relative standard error is 5% in that case the number of verticals is two, notice that with a $\frac{V^2}{D}$ index of 3 the number of verticals is five. When the discharge of sand-sized particles is of primary interest the 100-percent line should be used regardless of the amount of fines in the sample.

The Equal Discharge Increment Method (EDI)

This method currently used by the DPMA's Teams consists in sampling verticals which are located at the so-called centroids of equal discharge increment, that is, the cross-section is divided into subsections through which the same discharge passes. The mean concentration for the entire cross-section is the average of the several verticals, namely,

$$\bar{c} = \frac{\sum_{i=1}^n c_i}{n} \quad (11)$$

If all samples are of the same volume, they can be composited, that is, they can be combined into one container and the concentration of the composite sample will be the mean concentration. See Annex III for the proof. We quote Guy "Field Methods for Measurement of Fluvial Sediment".

The EDI method, in which samples are obtained at the centroids of equal discharge increments, is usually limited to streams with stable channels where discharge ratings change very little during a year. The method requires that the fieldman have some knowledge of the stream-flow distribution in the cross section before sampling verticals can be selected. If such knowledge can be obtained, the EDI method can save time and labor over the ETR method, especially on the large streams, because fewer verticals are required.

To make the EDI measurement when prior flow knowledge is not available or applicable, it is necessary to determine first the total discharge of the stream in increments across the channel. This is done in accordance with methods described by Carter and Davidian (1968) and Buchanan and Somers (1969). From a discharge measurement, a graph is drawn of cumulative discharge in percent of total discharge versus distance from the left or right bank of the station numbers on the cableways or bridges. (See fig. 23 .) A decision is then made, or was made in the office, as to the number of verticals required to adequately define the suspended-sediment concentration across the stream. For example, if only four verticals are needed, then a sample would be taken at the stations where for a given discharge, the mid-point of accumulation (centroids) of discharge increments of 25 percent occur, that is, at stations of cumulative discharges of 12, 38, 62 and 88 percent.

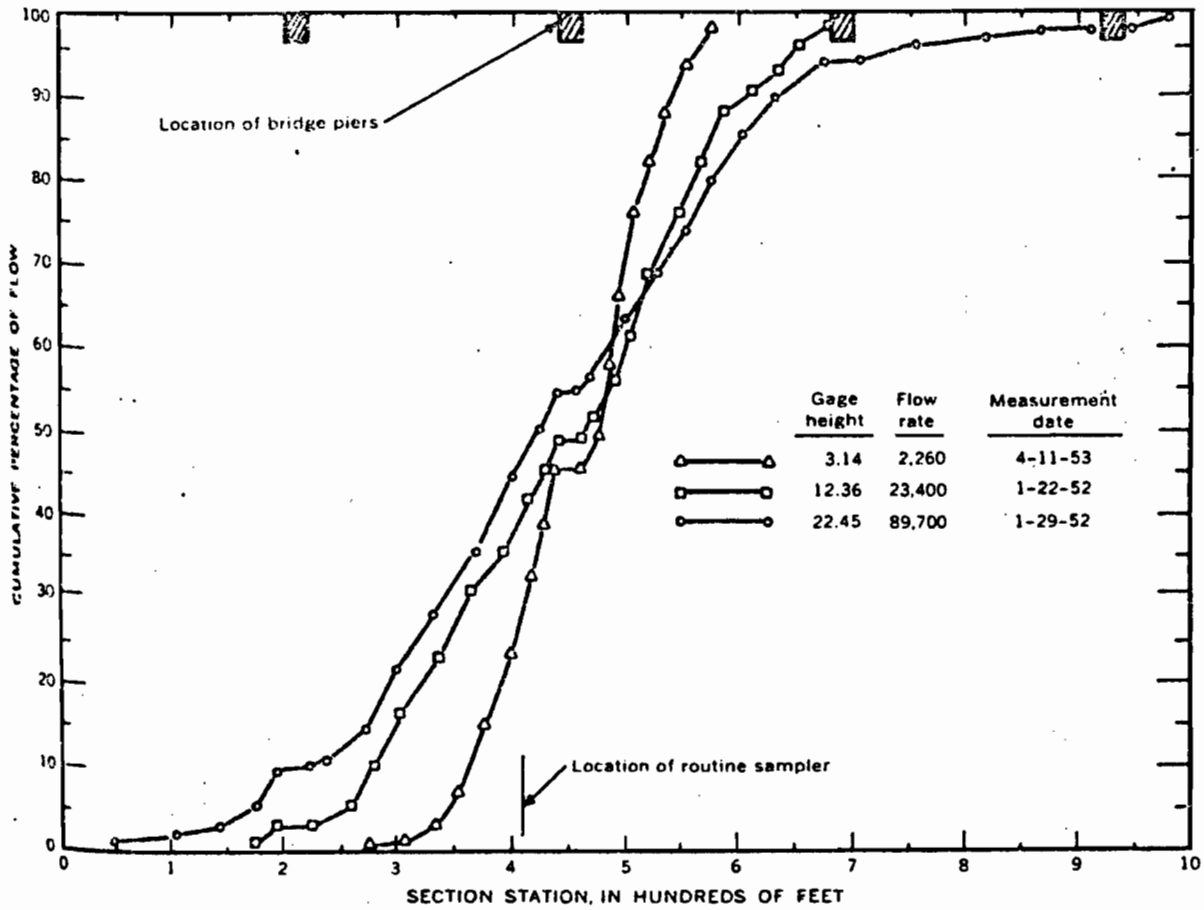

Fig 23.—Cumulative percentage of the total water discharge for three rates of flow with distance across a stream section. The graph is used to estimate the location of the centroids-of-equal-discharge increments. Gage height in feet; flow rate in cubic feet per second.

At each of the desired centroid stations, two or more bottles are taken by the depth-integration method to represent two or more cross-section samples. Thus, the contents of each bottle is proportional to 25 percent of the water discharge for each respective sample. If the two (or more) sets of samples are to be analyzed only for the total concentration across the stream, then laboratory time can be saved if each bottle has nearly the same quantity of sample so that the four bottles representing the total flow (each sample) can be composited. See Annex III.

On most streams, where the EDI method is used many times each year, a set of curves is drawn for several rates of water discharge or stages of flow. These can then be transformed into a set of sampling instructions which are kept in the stage-recorder shelter at the site or in the field vehicles.

Sand-bed streams characteristically shift radically at single points and from one side to the other, both over a period of weeks or in a matter of hours. This not only makes it impossible to establish percentage-discharge curves applicable from one visit to the next, but one cannot be certain the discharge distribution does not change between the water-discharge measurement and the sampling for the sediment measurement. Obviously, for sand-bed streams and for new sediment-measuring sites, the main disadvantage to the EDI method is that a water-discharge measurement must precede the sediment-discharge measurement. However, in some instances where detail is not required, it may be possible for the fieldman to estimate equal increments of flow and sample at their centroids without a detailed water-discharge measurements.

The Equal Transit Rate Method (ETR)

In that method the sampled verticals are uniformly spaced and the same transit rate is used for all verticals. The mean concentration is the ratio of the total weight of sediment to the total volume of the water-sediment-mixture collected, in other words the samples are composited into a simple one whose concentration is the mean concentration for the whole stream. See Annex III for proof.

Here again we quote GUY:

A cross-sectional suspended-sediment sample obtained by the ETR method requires a sample volume proportional to the amount of flow at each of several equally spaced verticals in the cross section. This equal spacing between verticals across the stream and an equal transit rate (ETR), both up and down in all verticals, yields a gross sample proportional to the total streamflow. Obviously, it is necessary to keep the same size nozzle in the sampler for a given measurement. This method was first used by B. C. Colby in 1946 (F.I.A.S.P., 1963b, p.41) and is used most often in shallow and (or) sand-bed streams where the distribution of water-discharge in the cross section is not stable.

The number of verticals required for an ETR sediment-discharge measurement depends on the streamflow and sediment characteristics at the time of sampling as well as on the desired accuracy of the result. On many streams, both statistical approaches and experience are needed to determine the desirable number of verticals. Until such experience is gained, the number of verticals used should be on the high side for each set, even though the result may be over-sampling. Through general experience with similar streams, the fieldman can estimate the required minimum number of verticals to yield a desired level of accuracy. For all but the very wide and shallow streams, twenty verticals are usually ample.

The width of the segments to be sampled or the distance between verticals is determined by dividing the stream width by the number of verticals decided upon. The stream width, of course, is determined from a tagline stretched across the stream or from station markings on cableways and bridge railings. For example, if the stream width is 53 m and the minimum number of verticals needed is 10, then the width of segment to be sampled is 5.3 m. To be practical, and since 10 verticals is the minimum number of verticals, the fieldman would use a vertical spacing of 5 m. The location of his first vertical would theoretically be at station 2.5 m. Then, the second vertical would be at $5 + 2.5 = 7.5$ m and so on, thus

sampling at the midpoint of flow segments 5 m wide.

Though the final section would be 8 m instead of 5 m the sampling results will not be measurably affected because the amount of flow in the segments near the banks is usually small in comparison with the midstream segments.

Because the maximum transit rate must not exceed $0.4 \bar{U}$ and because the minimum must be sufficiently fast to keep from overflowing any of the sample bottles, it is evident that the transit rate to be used for all verticals is limited by conditions at the vertical containing the largest discharge per unit of width (largest product of depth times velocity). A discharge measurement can be made to determine where this vertical is located, but generally it is estimated by sounding for depth and acquiring a "feel" for the relative velocity with an empty sampler or wading rod. The transit rate required at the maximum discharge vertical must then be used at all other verticals in the cross section and is usually set to fill a bottle in a round trip.

In slow-moving water it is sometimes tiring and awkward to use an extremely slow transit rate, especially when using a handline or when wading. Under such circumstances, it may be advisable to increase the transit rate and make two or more trips in each vertical. This generally results in a more "natural" transit rate and provides a better averaging of possible variations. In streams with very low velocities in the maximum flow section, the sediment is generally fine material and the sampled concentration would be unaffected by a possible transit rate somewhat faster than $0.4 V_m$ in some verticals.

The ETR method has some important advantages over the EDI method. First, it is apparent that a previous water-discharge measurement is not required. Another advantage of the ETR is that analysis time and effort can be saved in the laboratory because the sample bottles are composited to give one cross-sectional sediment concentration and (or) particle-size gradation. On the other hand, because of the difficulty in maintaining an equal rate of integration of each vertical and the bottle shortage the ETR method has limited applications at most sites.

VI. OTHER MEASUREMENT DEVICES

Instantaneous Samplers

The principle of operation of an instantaneous sampler is simple. An open container, either in a vertical or horizontal position, is lowered to the desired location. Then some kind of a device releases a mechanism which traps the sample of the water-sediment mixture. As can be imagined, numerous samplers based on such a principle have been designed all over the world. Generally, they may have most any capacity, but usually they vary from trapping about 1 to 5 liters of mixture. They are introduced into the water by rods (for shallow depth) or by cables or ropes.

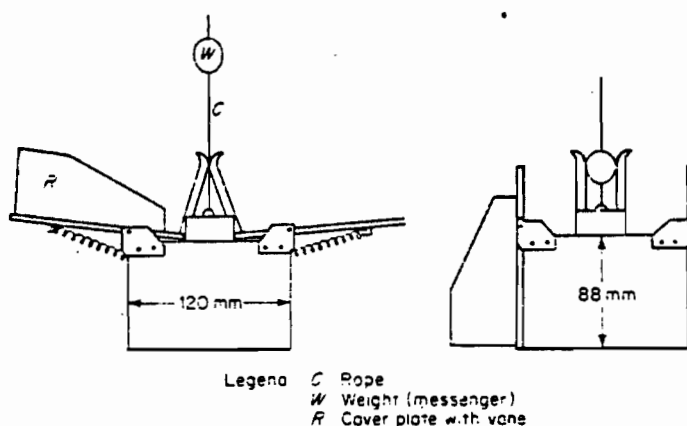

Fig. 24 Instantaneous horizontal sampler. [After JAKUSCHOFF (1932).]

A typical horizontal sampler, discussed by JAKUSCHOFF (1932), is shown in Fig. 24. It consists of a pipe, two cover plates, metal weight, and a rope. upon release of the metal weight, the cover plates enclose a sample of the sediment-water mixture into the pipe.

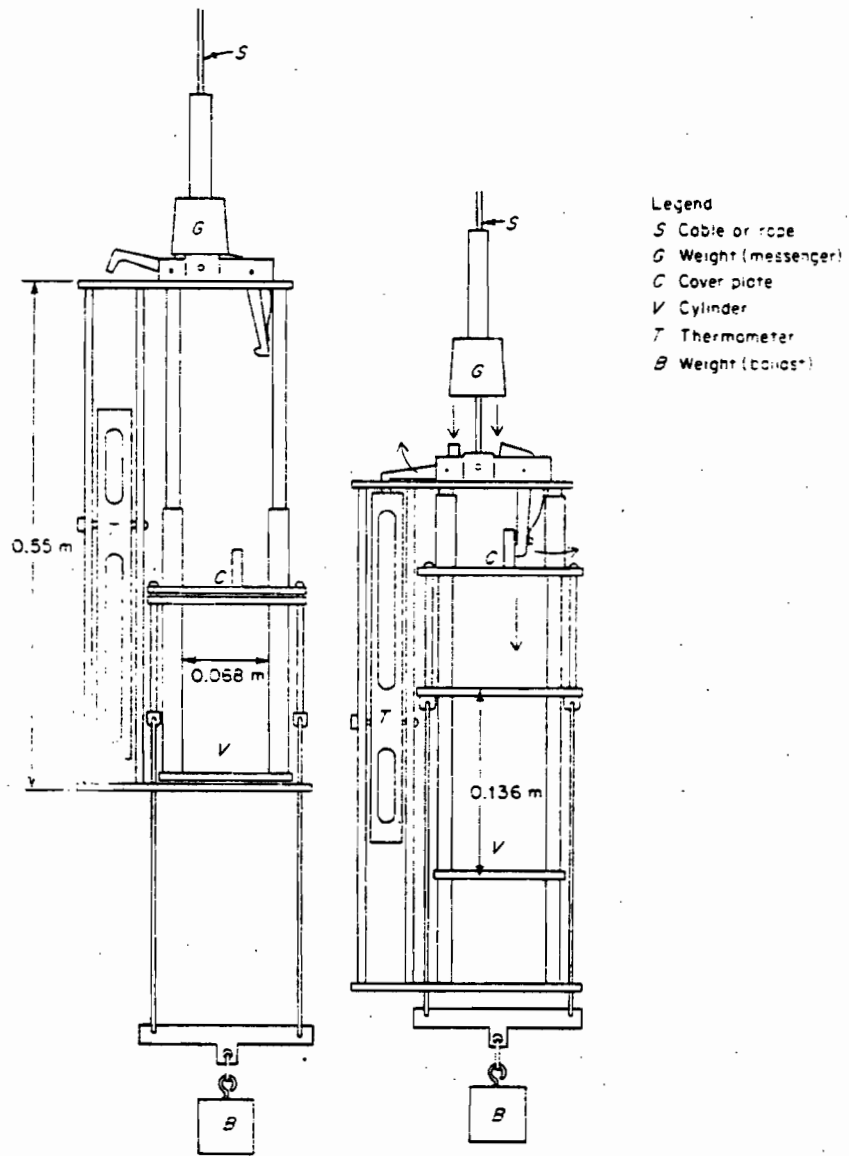

Fig. 25 Instantaneous vertical sampler. [After JAKUSCHOFF (1932).]

In fig. 25 is shown a vertical sampler. It consists of a cylinder and a cover plate, a metal weight and cable. If the device is in the sampling position, the metal weight called messenger is sent down the cable, releases the cover plate which drops and encloses the sample into the cylinder.

Single-Stage Sampler

These samplers are in fact point-integrating samplers designed to get samples at flood stage when manual sampling would be difficult for instance on small fast-rising streams where it is impractical to use a conventional depth-integrating sampler.

The U.S. U59 was developed for automatic collection of samples without immediate attention from field personnel. Several of these units may be mounted at one station at different stages. The sampler consists of a bottle mounted on a rack. A stopper with two holes, one for the syphon-shaped air exhaust the other for the intake tube, seals the bottle. The water-sediment mixture enters whenever the water level rises to the elevation at which the intake nozzle is placed. A single stage sampler is presented in fig. 26 with both a vertical and a horizontal intake.

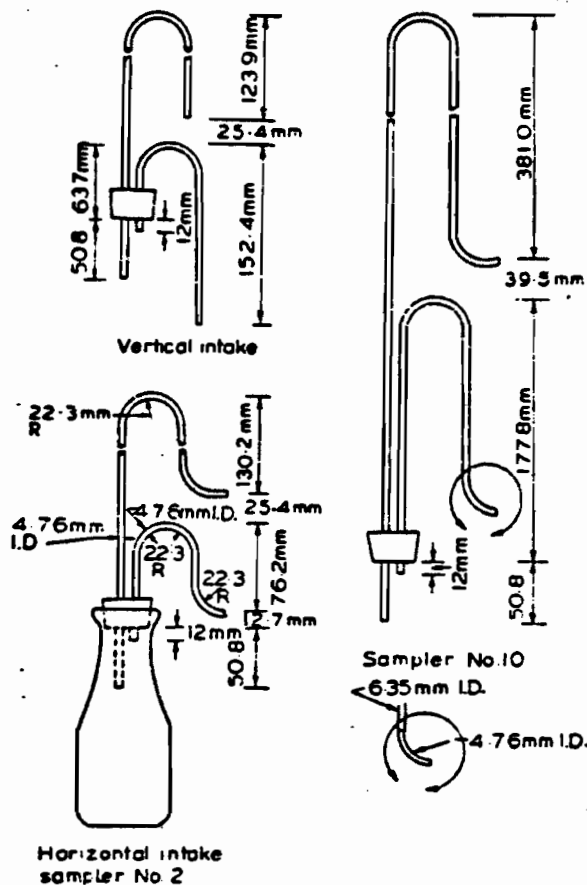

Figure 26: Single-stage suspended - sediment sampler U.S.U-59

The Gluschkoff Bellows (Shown in Fig. 27)

A deflated rubber bag is brought into the measuring position. The draw tube at the rubber bag is now held into the flow, and the rubber bag begins to fill. Just before the rubber bag is filled, the draw tube is turned and the filling time recorded. Both the flow rate and the suspended load can be determined.

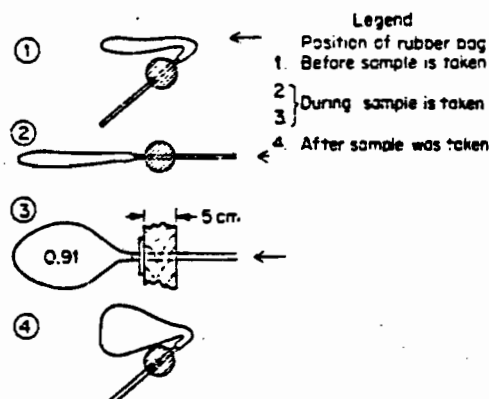

Fig. 27 Gluschkoff's bellows.
 After DEBSKI (1965).]

Pumping Samplers

These samplers consist of a pumping system with the intake located in the stream at a preselected stage and the outlet going to a bottling or flushing system. They are designed to obtain a continuous record of sediment concentration by sampling at specific time intervals according to the nature of the stream. Despite the facts that the velocity in the intake is not equal to the stream velocity and that the intake itself does not point into the flow they can provide complete coverage of storm events which would be otherwise difficult or even impossible to obtain. The experiments carried out so far show that only coarse particles are affected by this type of sampling.

ORSTOM Procedure

Developed since 1966 by ORSTOM (Office de la Recherche Scientifique et Technique Outre-Mer in France) in several West African countries this procedure consists in pumping the water-sediment mixture at several stages along a vertical through an intake nozzle welded to a plate fastened to a streamlined sounding weight so that to make sure the nozzle point into the flow. Velocities are measured at the sampled points along the vertical and the same is done at several verticals. The hand-operated pump is located at the surface in a boat along with the containers and the usual equipment used to perform water-discharge measurements. This procedure is interesting to measure low concentrations in relatively deep slow-moving streams where it is required to get several liters of water-sediment mixture at each point to obtain a good accuracy and where it is likely that fine sediments are not mixed uniformly throughout the cross section. An interesting feature is the relatively low cost of the equipment.

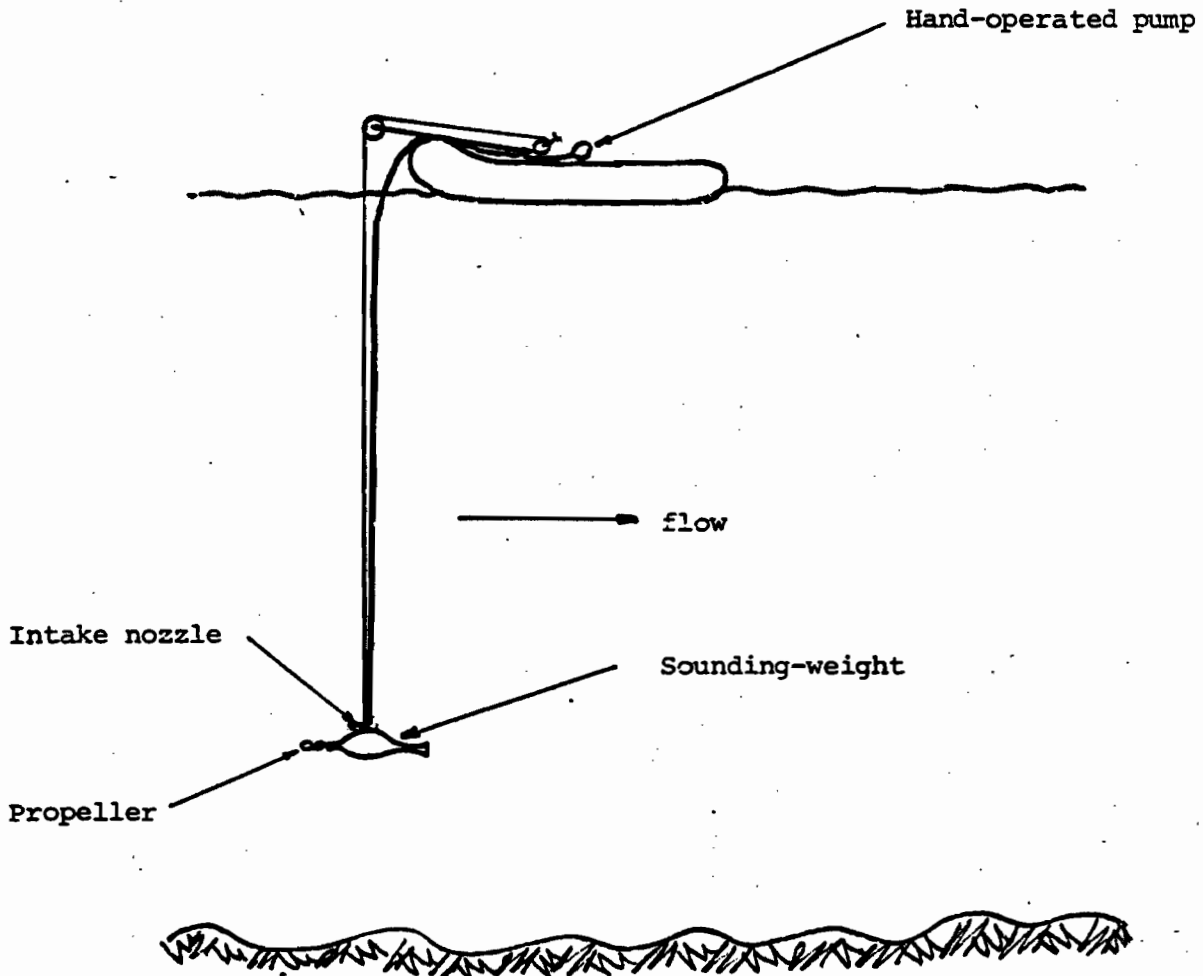

"Photoelectric Turbidity Meter" Method

This method is based on the principle that suspended solid particles make the liquid less transparent, this effect may be used to measure concentration by means of a turbidity sensor assuming that turbidity and concentration are closely related. Though many criticisms have been raised at the use of such instruments it seems that good results can be obtained, providing an instrument is field calibrated for a particular site and it is used on a small or medium-sized basin with relatively homogeneous rock type and a predominantly silt and clay-sized load. The fact that they allow to monitor continuously the sediment concentration largely offsets their shortcomings.

VII. CONCLUDING REMARKS

Most of the time and as far as daily record stations are concerned taking care of sampling is left to observers living near the sampling sites.

Usually the observer collects samples at a single vertical on a regular basis, the sythm of sampling based on the stream regime is set in advance. The observer must be carefully instructed how to operate the available equipment for different ranges of gauge heights.

When performing depth integrating sampling emphasis should be put on the following points:

- To sound the depth prior to sampling
- To adapt the transit rate, R_t , by a trial and error procedure
- To raise the sampler as soon as it touches the bottom of the stream
- To discard any "suspect" sample.

To "calibrate" samples obtained at a fixed single vertical more complete measurements are carried out by teams of the Hydrochemistry Branch during routine visits.

The main problem remains to measure sediment discharges during high flows and floods since it is widely accepted that the major part of the annual suspended sediment transport takes place during such events. To ascertain whether measuring sediment transport will be difficult one may rely on the following consideration : if at a gauging station measuring water discharges during high flow has proved to be a difficult task it is most likely that measuring sediment discharges will be even more difficult. Unfortunately as the rating curves witness, numerous Indonesian rivers present features which are not conducive to easy measurements of both water and sediment discharges.

It is all very well to carry out careful measurements during low and medium flows, but one must keep in mind that from a sediment transport point of view high flows and floods have in most cases a more important bearing on the yearly amount of sediment transported. So we should caution against a widespread attitude consisting in doing nothing when the prevailing hydraulic

conditions prevent from performing orthodox measurements. Once more we refer to Guy

"At some locations stream velocities are so great that even 100 pounds samplers cannot penetrate the water more than a short distance before they are dragged downstream and out of the water in an erratic movement. Under such conditions, it can be expected that all except the largest particles of sediment will be thoroughly mixed with the flow and therefore a sample near the surface is very worthwhile. A sample obtained by lowering an uncapped bottle is better than no sample at all".

Even if heavy point-integrating samplers were available and to the best of our knowledge they are not it is dubious that an observer could handle them alone, so as one cannot expect a team from the DPMA to be always present during high flows the last resort is, beyond a certain stage, to take surface samples which will be calibrated by comparison with more detailed measurements. We recommend to train the observer to take surface samples as well as depth integrated samples and to set in advance the stage beyond and below which he will have to use either of the two methods this can be readily done through study of past water-discharge measurements and in accordance to the type of sampler at his disposal.

To resume an observation made by Mr. J. Knott, U.N. sediment specialist we remind of the necessity to use a suspension reel which allows a sampler to operate to its full capacity. For example, it is obvious that the reel must allow to lower and raise the sampler at the chosen transit rate, if not it is pointless to try and perform a depth-integrated measurement since this will result in overfilling the sample bottles.

Last but not least we think that the notion of relative error is frequently forgotten though it is of primary importance when measuring in the field. For example, let us assume that in a given stream sand-sized particles represent 15 per cent of the total suspended load, surface sampling may give rise to an error as high as 100 per cent as far as sand particles are concerned, however, if the aim is to determine the total suspended load the resulting error will be in the region of 20 per cent which is far less serious than not measuring at all and relying on "guesstimates" or dubious extrapolations which are in our opinion the worst thing to do.

Annex I

Depth Integrating Method

In that method the sampler runs the vertical at a uniform speed, that is, it is lowered from the surface to the bottom with a so-called transit rate which is kept constant. The concentration of the sample collected continuously during the trip represents the mean concentration at the vertical which has previously been defined as :

$$\bar{c} = \frac{\int_0^D c u dy}{\int_0^D u dy} \quad (7)$$

Let us prove it :

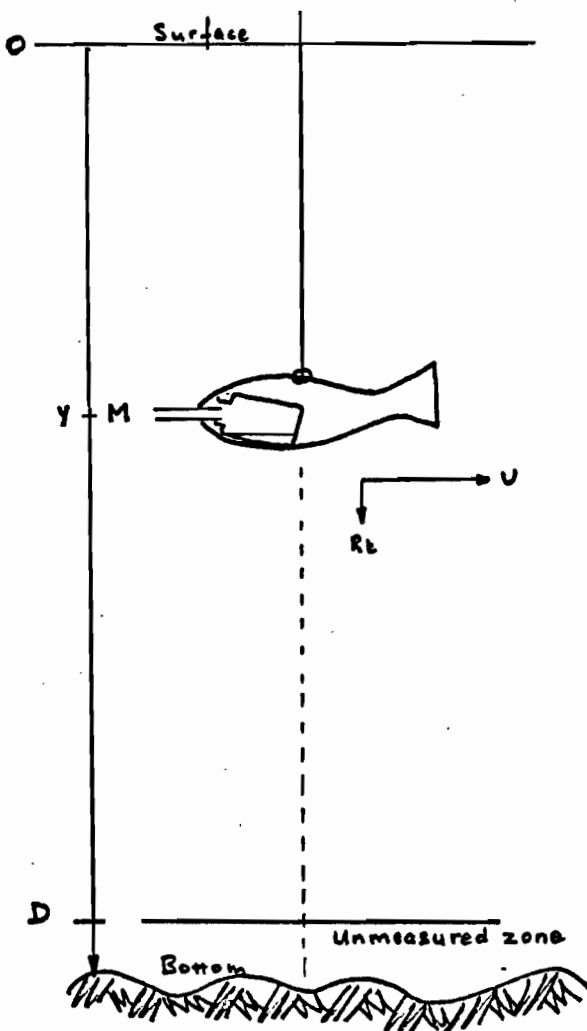

Let us consider the sampler as it goes past a point M. During a little increment of time Δt a small volume, Δv , of water-sediment mixture enters the bottle. Let us denote, a , the nozzle area, u , the stream velocity at and around M, R_t , the transit rate and, c , the concentration of suspended sediment at and around M.

So we have :

$$(i) \quad \Delta v = au \Delta t$$

The weight of sediment for a volume Δv collected at the point M is:

$$(ii) \quad \Delta w = c \Delta v$$

During Δt the sampler had been lowered along a depth increment Δy such as:

$$(iii) \quad \Delta y = R_t \Delta t$$

Combining (i) (ii) and (iii) we get:

$$\Delta w = \frac{acu}{R_t} \Delta y$$

$$\Delta v = \frac{au}{R_t} \Delta y$$

Integrating over the whole depth we have for the weight of sediment collected during a single trip from surface to bottom:

$$w = \int_0^D cu \frac{a}{R_t} cudy$$

likewise for the volume of the sample

$$v = \int_0^D u \frac{a}{R_t} udy$$

As the concentration of the sample obtained this way is the ration of the weight of sediment to the volume of the water-sediment mixture, taking into account that both, a , and R_t , are constant we get:

$$\frac{w}{v} = \frac{\int_0^D cudy}{\int_0^D udy}$$

which is indeed the mean concentration for the measured part of the vertical defined by equation (7).

Let us assume that the sampler is raised from the bottom to the surface with a different transit rate R'_t , we have for the total weight of sediment :

$$w = \frac{a}{R_t} \int_0^D cudy + \frac{a}{R'_t} \int_D^0 cudy$$

and for the volume

$$v = \frac{a}{R_t} \int_0^D udy + \frac{a}{R'_t} \int_D^0 udy$$

The ratio of w to v , that is, the concentration of the sample collected in a round trip is :

$$\frac{w}{v} = \frac{\frac{a}{R_t} \int_0^D cudy + \frac{a}{R'_t} \int_D^0 cudy}{\frac{a}{R_t} \int_0^D udy + \frac{a}{R'_t} \int_D^0 udy}$$

but it is obvious that

$$\int_0^D cudy = \int_D^0 cudy$$

and

$$\int_0^D udy = \int_D^0 udy$$

So we have

$$\frac{w}{v} = \frac{\left(\frac{a}{R_t} + \frac{a}{R'_t}\right) \int_0^D cudy}{\left(\frac{a}{R_t} + \frac{a}{R'_t}\right) \int_0^D udy} = \frac{\int_0^D cudy}{\int_0^D udy} = \bar{c}$$

There again we can conclude that the ratio $\frac{w}{v}$ is equal to the mean concentration over the vertical.

When it is necessary to divide the vertical into several intervals, for instance, in case of great depths or high velocities a point-integrating sampler can be used to perform depth integration provided that each interval is run with the same transit rate for a given direction.

The samples collected in such a way can be composited and the concentration of the composite sample is equal to the mean concentration.

Let us assume that the vertical is divided into n intervals we have for the total weight of sediment W :

$$W = \sum_1^n w_i = \frac{a}{R_t} \int_0^{y_1} cudy + \frac{a}{R_t} \int_{y_1}^{y_2} cudy + \dots + \frac{a}{R_t} \int_{y_i}^{y_{i+1}} cudy + \dots + \frac{a}{R_t} \int_{y_{n-1}}^{y_n=D} cudy$$

and for the total volume V :

$$V = \sum_1^n v_i = \frac{a}{R_t} \int_0^{y_1} udy + \dots + \frac{a}{R_t} \int_{y_i}^{y_{i+1}} udy + \dots + \frac{a}{R_t} \int_{y_{n-1}}^{y_n=D} udy$$

w_i and v_i are the weight of sediment and the volume of mixture collected by the sampler while running the interval i . Following the rules of the integral calculus we can write

$$W = \sum_1^n w_i = \frac{a}{R_t} \int_0^D cudy$$

$$V = \sum_1^n v_i = \frac{a}{R_t} \int_0^D udy$$

and the concentration of the composite sample that is the ration of W to V is indeed the mean concentration over the vertical since

$$\frac{W}{V} = \frac{\int_0^D cudy}{\int_0^D udy} = \bar{c}$$

Annex IIPoint Integrating Method

In that method concentrations are measured at several points along the vertical. A point integrating sampler is used, that is, a sampler equipped with a valve to control both the opening and the closing of the intake nozzle through a remote control.

To avoid the burden of measuring both velocities and concentrations at the same time the following procedures can be followed to determine the mean concentration over the vertical.

Let us divide the vertical in equal intervals at the center of which samples are taken and let us denote them 1, 2, ..., i, ..., n, furthermore let us assume that both velocity and concentration are constant throughout each interval this is justified as far as the depth of each interval is small enough.

Formula 7 can be expressed as the ratio of two finite sums :

$$\bar{c} = \frac{\sum_{1}^{n} c_i u_i \Delta y_i}{\sum_{1}^{n} u_i \Delta y_i} \quad (7')$$

and since $y_1 = y_2 = \dots = y_n$ we get :

$$\bar{c} = \frac{\sum_{1}^{n} c_i u_i}{\sum_{1}^{n} u_i} \quad (7'')$$

For the interval, i , the weight and volume of the sample collected are respectively

$$w_i = a T_i c_i u_i$$

$$v_i = a T_i U_i$$

T_i being the sampling time and, a , the nozzle area

Now if the samples numbered from 1 to n are composited the weight of the composite sample would be

$$W = \sum_1^n w_i = \sum_1^n a T_i c_i u_i$$

and the volume

$$V = \sum_1^n v_i = \sum_1^n a T_i u_i$$

If the sampling time had been kept the same for each sample, that is, $T_1 = T_2 = \dots T_n$, for the concentration of the composite sample we would obtain :

$$\frac{W}{V} = \frac{aT \sum_1^n c_i v_i}{aT \sum_1^n u_i} = \frac{\sum_1^n c_i u_i}{\sum_1^n u_i} = \bar{c}$$

which is the mean concentration over the vertical defined by formula (7").

If the sampling time is not kept constant the samples cannot be composited since they are not equally time weighted. In that case each sampling time must be recorded, weight of sediment and volume of water-sediment mixture are determined in the laboratory for each sample and divided by the corresponding sampling time, that amounts to compute the weight of sediment and the volume of the mixture which would have been collected for a unit time and the mean concentration is obtained through the following formula

$$\bar{c} = \frac{\sum_1^n \frac{w_i}{T_i}}{\sum_1^n \frac{v_i}{T_i}} = \frac{\sum_1^n c_i u_i}{\sum_1^n u_i}$$

Since $\frac{w_i}{T_i} = c_i u_i$ and $\frac{v_i}{T_i} = u_i$

Obviously if the samples are not equally spaced along the vertical samples cannot be composited and formula (7') must be used, that is for each point, both weight of sediment and volume of mixture have to be weighted by the corresponding depth.

Annex IIIEDI and ETR Methods

The problem is to determine the mean concentration for the whole cross section which is denoted, \bar{c} , and defined as the ratio of the sediment discharge to the water discharge, namely :

$$\bar{c} = \frac{\iint_A c u dx dy}{\iint_A u dx dy}$$

Let us divide the cross section into subsection denoted x_1, x_2, \dots, x_n

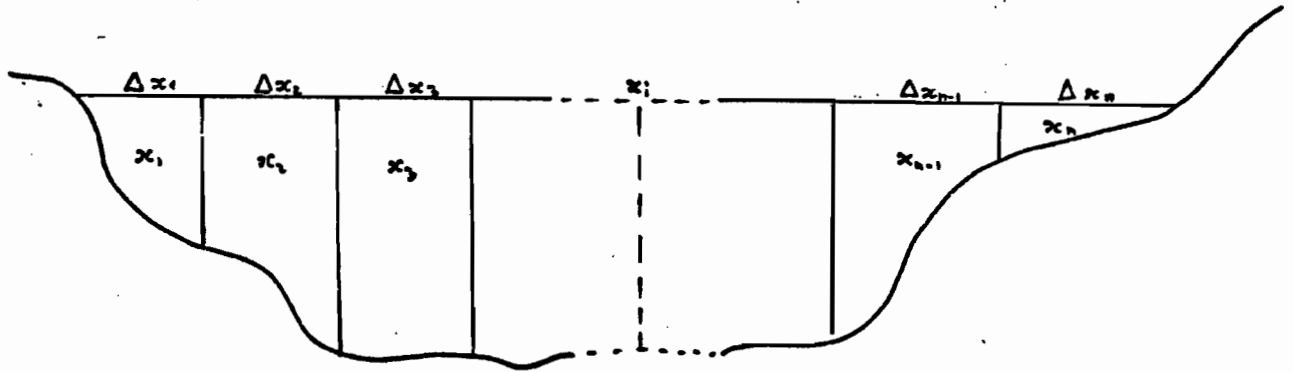

lengths of which at the surface are denoted $\Delta x_1, \Delta x_2, \dots, \Delta x_n$ and such that

$$\sum_1^n \Delta x_i = \text{width of the stream.}$$

It is assumed that the mean concentrations $\bar{c}_1, \bar{c}_2, \dots, \bar{c}_n$ are known and so are the water discharges q_1, q_2, \dots, q_n for each sub-section.

Both formulae (9) and (10) can be written in the form of finite sums.

We have for the suspended sediment discharge

$$Q_s = \sum_1^n \bar{c}_i q_i \Delta x_i$$

for the water discharge

$$Q = \sum_1^n q_i \Delta x_i$$

and for the mean concentration

$$\bar{c} = \frac{\sum_1^n \bar{c}_i q_i \Delta x_i}{\sum_1^n q_i \Delta x_i} \quad (9')$$

In the EDI method the sampled verticals are located at the centroids of Equal Discharge Increment, that is, $q_1 = q_2 = \dots = q_n = \frac{Q}{n}$

So we get for \bar{c}

$$\bar{c} = \frac{\frac{Q}{n} \sum_1^n \bar{c}_i}{Q} = \frac{\sum_1^n \bar{c}_i}{n}$$

that is, the arithmetic mean of the concentrations at verticals x_1, x_2, \dots, x_n .

In order to save time or if particle-size analysis is needed the samples collected at the different verticals may be composited provided that all samples are of the same volume or nearly the same.

Let us prove it.

For a given vertical, x_i we have :

$$\bar{c}_i = \frac{w_i}{v_i} \quad (\text{depth-integrating method})$$

and as far as the EDI method is used

$$\bar{c} = \frac{\sum_1^n c_i}{n} = \frac{\sum_1^n \frac{w_i}{v_i}}{n}$$

if $v_1 = v_2 = \dots = v_i = \dots = v_n = \frac{v}{n}$ then

$$\bar{c} = \frac{\sum_1^n w_i}{v}$$

that is, the ratio of the weight of sediment to the volume of the composite sample or its concentration.

In the ETR method (Equal Transit Rate) the sampled verticals are equally spaced and the transit rate is kept constant for all verticals. In that case the samples collected at the different verticals may be composited and the mean concentration, \bar{c} , is the concentration of the composite sample.

Let us prove it.

The volume of water sediment mixture collected at a vertical, i , during a single trip using a constant transit rate is :

$$v_i = \int_0^D \frac{a}{R_t} u \, dy$$

or since, a , and R_t , are constant

$$v_i = \frac{a}{R_t} \int_0^D u dy = \frac{a}{R_t} q_i$$

so we have for \bar{c}_i

$$\bar{c}_i = \frac{w_i}{\frac{a}{R_t} q_i}$$

it follows that

$$\bar{c}_i q_i = \frac{w_i}{\frac{a}{R_t}} \quad \text{and} \quad q_i = \frac{v_i}{\frac{a}{R_t}}$$

Substituting in equation (9') we get :

$$\bar{c} = \frac{\sum_1^n \bar{c}_i q_i \Delta x_i}{\sum_1^n q_i \Delta x_i} = \frac{\sum_1^n \frac{R_t}{a} w_i \Delta x_i}{\sum_1^n \frac{R_t}{a} v_i \Delta x_i}$$

Since by hypothesis $R_t, a, \Delta x_i$ are constant we get

$$\bar{c} = \frac{\sum_1^n w_i}{\sum_1^n v_i}$$

which indeed represents the concentration of the composite sample.

We based our reasoning on the sampler making a single trip but the reasoning holds true if the sampler makes a round trip provided that during the return trip the vertical be run with the same transit rate. Obviously, the nozzle must be kept unchanged for all the verticals.

References

- Field Methods for Measurement of Fluvial Sediment by Harold P. Guy and Vernon W. Norman. U.S. Geological Survey
- Sedimentation Engineering, Vito A. Vanoni Editor. American Society of Civil Engineers
- Hydraulics of Sediment Transport by Walter H. Graf. McGraw-Hill
- "Methodology for the measurement of suspended load from intertropical rivers, in the frame of a network" by J.F. Nouvelot. Cahiers ORSTOM Vol.IX 1972, in French
- Final Report of Sediment Specialist by James M. Knott. DPMA, UNDP.